



# THUMPER FAB

Aluminum Audio Roofs ♦ Roll Cages ♦ UTV Accessories

## CF Moto U10 Pro Long Travel Kit

SKU: TF282001



### Thumper Fab

5103 Elysian Fields Rd, Marshall, TX 75672

Customer Service: 903-472-0928

[www.thumperfab.com](http://www.thumperfab.com)

Ver. 0426

# CF Moto U10 Pro

## Long Travel Kit

SKU: TF282001



### PARTS

REF	QTY	DESCRIPTION
1	1	Front Upper Driver Control Arm
2	1	Front Upper Passenger Control Arm
3	1	Front Lower Driver Control Arm
4	1	Front Lower Passenger Control Arm
5	1	Rear Upper Driver Control Arm
6	1	Rear Upper Passenger Control Arm
7	1	Rear Lower Driver Control Arm
8	1	Rear Lower Driver Control Arm
9	2	Front Axles
10	2	Rear Axles
11	2	Tie Rod Assemblies
12	2	Front Shock Relocation Brackets
13	2	Front Shock Spacers (Long)
14	2	Rear Shock Relocation Sandwich Plate
15	1	Rear Shock Relocation Bracket - DR
16	1	Rear Shock Relocation Bracket - PA
17	2	Rear Shock Spacers (Short)
18	1	Brake Line Kit
19	2	Steering Stops
20	2	Hose Clamps
<b>HARDWARE KIT - OEM SHOCK RELOCATION</b>		
A	4	M8x25mm Flange Head Bolt
B	4	M8 Flange Nylon Lock Nut
C	2	M12x70mm Flange Head Bolt
D	4	M12x80mm Flange Head Bolt

### TOOLS

- 1/4" Socket
- 10mm Socket and Wrench
- 13mm Socket and Wrench
- 15mm Socket and Wrench
- 16mm Socket and Wrench
- 17mm Socket and Wrench
- 18mm Socket and Wrench
- 19mm Socket and Wrench
- 30mm Socket
- Drill and 1/4" Drill Bit
- Snips
- Needle Nose Pliers
- Large Channel Locks
- Flathead Screwdriver
- Rubber Mallet
- Small Hammer
- 4mm Allen Wrench
- Blue Loctite
- Anti-Sieze

Torque Specs:

SIZE (STANDARD)	GRADE 5	GRADE 8	SIZE (METRIC)	CLASS 8.8	CLASS 10.9
5/16"	15 ft/lbs	20 ft/lbs	6MM	5 ft/lbs	9 ft/lbs
3/8"	30 ft/lbs	35 ft/lbs	8MM	10 ft/lbs	23 ft/lbs
7/16"	45 ft/lbs	60 ft/lbs	10MM	22 ft/lbs	45 ft/lbs
1/2"	65 ft/lbs	90 ft/lbs	12MM	55 ft/lbs	75 ft/lbs
9/16"	85 ft/lbs	130 ft/lbs	14MM	85 ft/lbs	120 ft/lbs
5/8"	135 ft/lbs	175 ft/lbs	16MM	130 ft/lbs	185 ft/lbs
3/4"	185 ft/lbs	280 ft/lbs	18MM	170 ft/lbs	240 ft/lbs

### BEFORE YOU BEGIN

If you do not feel comfortable installing your **Thumper Fab Long Travel**, please see your nearest **Thumper Fab® Dealer** for installation.

# CF Moto U10 Pro

## Long Travel Kit

SKU: TF282001



### PARTS

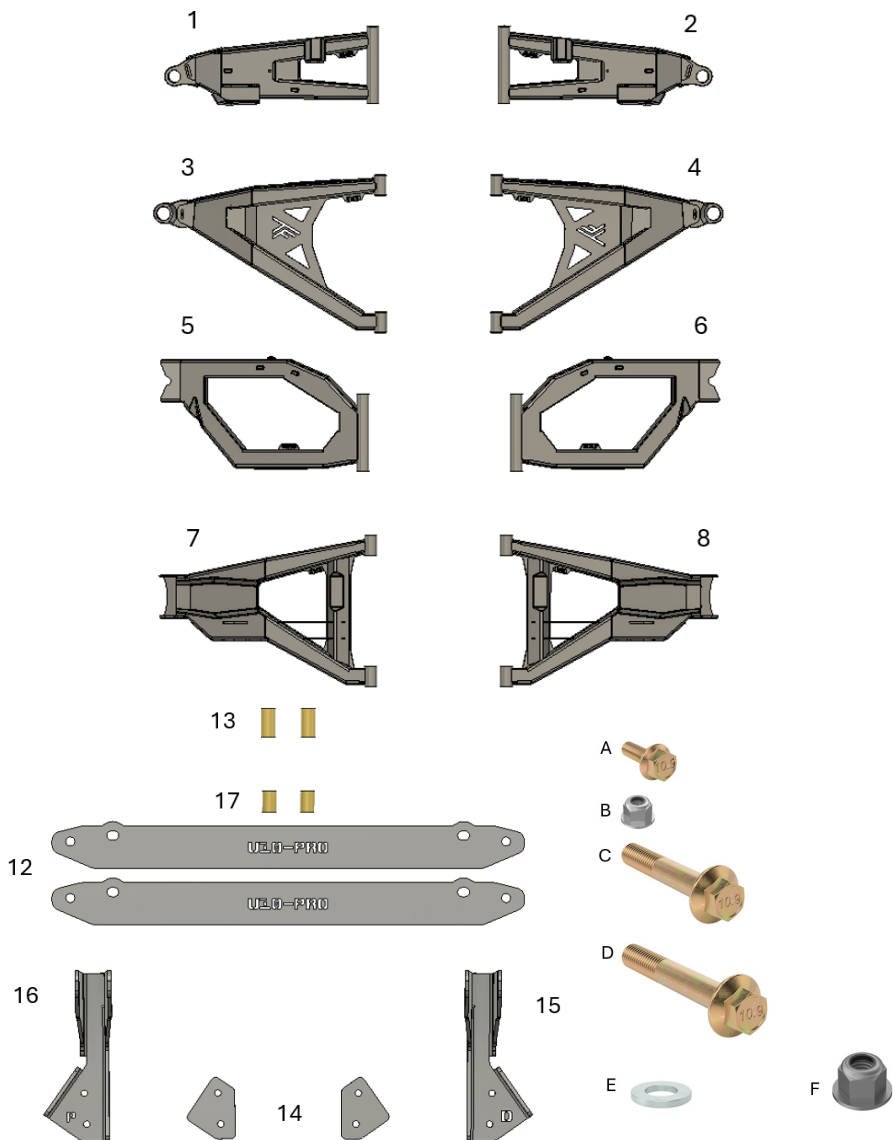

# INSTALLATION INSTRUCTIONS

## Front Installation Preparation

Begin by lifting the vehicle off the ground and remove the wheels and tires. Use a drill and a 1/4" drill bit to drill out the rivets that fasten the brake lines to the OEM control arms (**FIG 1 & FIG 2**).



**FIG 1 & FIG 2 - Drill out rivets that fasten the brake lines to the OEM control arms**

Remove the cotter pins from the front axle nuts using a pair of snips or needle nose pliers (**FIG 3 & FIG 4**).

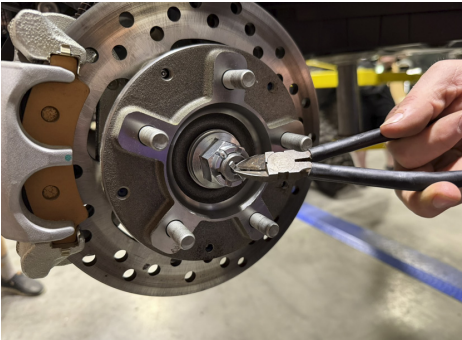

**FIG 3 & FIG 4 - Remove axle nut cotter pins**

# INSTALLATION INSTRUCTIONS

## Front Installation Preparation

Remove the axle nuts using a 30mm socket (**FIG 5**).



**FIG 5 - Remove the axle nuts**

Remove the cottens pins from the outer tie rod castle nut and remove the castle nut using a 19mm socket or wrench. Disconnect the tie rod from the knuckle (**FIG 6**).



**FIG 6 - Remove Tie Rod cotter pin and castle nut**

# INSTALLATION INSTRUCTIONS

## Front Installation Preparation

Remove the cottens pins from the upper and lower ball joint using a small flathead screwdriver and pliers (FIG 7 & FIG 8).

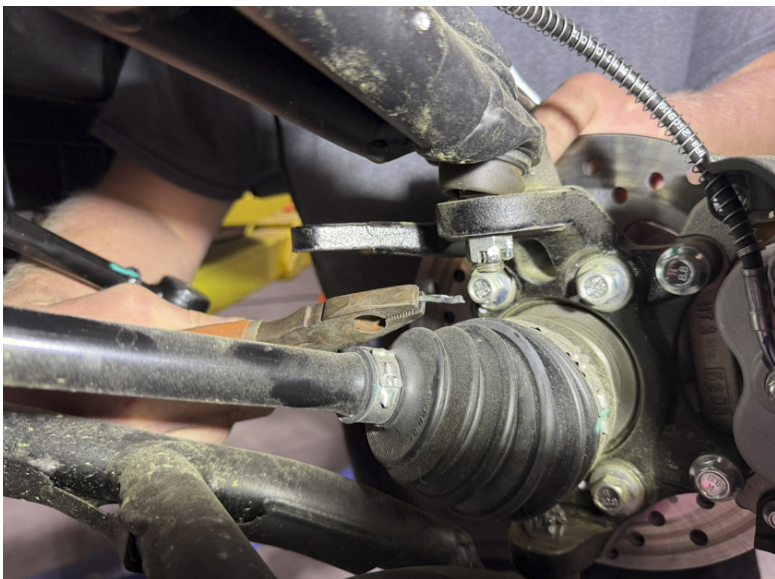

FIG 7 & FIG 8 - Remove ball joint cotter pin

# INSTALLATION INSTRUCTIONS

## Front Installation Preparation

Disconnect the brake line to the front calipers. Have a drain pan ready to catch the brake fluid that will leak out, keep the banjo bolt as it will be reused during installation (**FIG 9**).



**FIG 9 - Disconnect the front brake calipers**

Use a 19mm wrench to remove the ball joint castle nuts. Once removed use a small hammer to tap the knuckle to free the ball joints from the knuckle. Once the knuckle is loose, slide it off the axle and tie it up out of the way (**FIG 10 & FIG 11**).

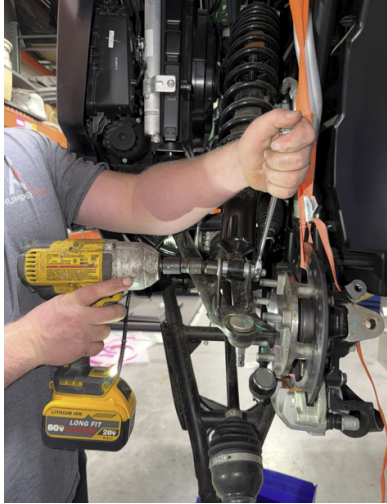

**FIG 10 & FIG 11 - Remove knuckle and tie up out of the way**

# INSTALLATION INSTRUCTIONS

## Front Installation Preparation

Disconnect the shock from the upper control arm using a 15mm socket and an 18mm wrench (**FIG 12**).



**FIG 12 - Disconnect the shock from the upper control arm**

Remove the flange lock nut that fastens the sway bar to the upper control arm using a 15mm socket (**FIG 13 & FIG 14**).

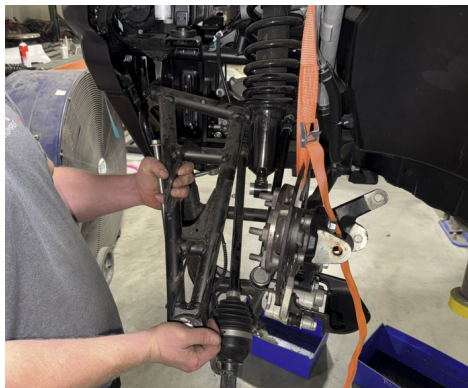
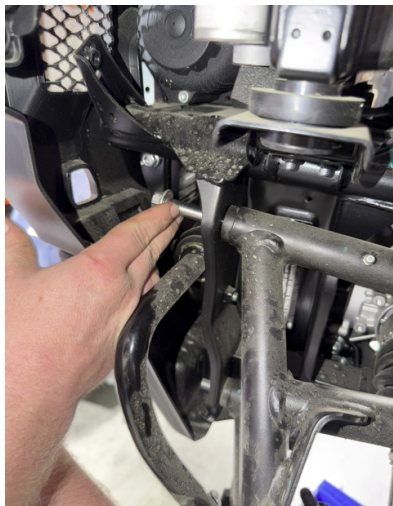

**FIG 13 & FIG 14 - Disconnect sway bar from upper control arm**

# INSTALLATION INSTRUCTIONS

## Front Installation Preparation

Remove the upper control arm mounting bolt using a 15mm socket and an 18mm wrench. Set aside the control arm (**FIG 15 & FIG 16**).



**FIG 15 & FIG 16 - Remove the upper control arm**

Remove the OEM front axles from the differential by pulling it out of the differential and setting aside (**FIG 17**).

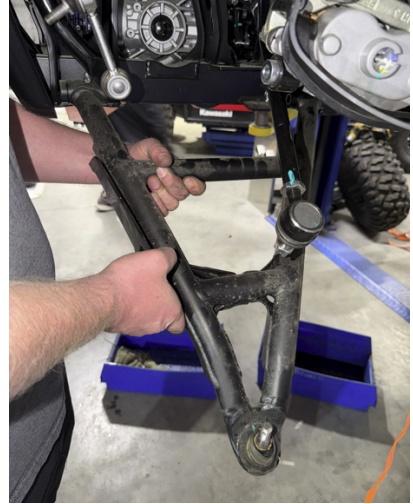

**FIG 17 - Remove the front axles**

# INSTALLATION INSTRUCTIONS

## Front Installation Preparation

Remove the lower control arm mounting bolts using a 15mm socket and an 18mm wrench. Set aside the control arm (**FIG 18 & FIG 19**).



**FIG 18 & FIG 19 - Remove the lower control arm**

Remove the front shock upper mounting bolt, set the shock aside (**FIG 20**).

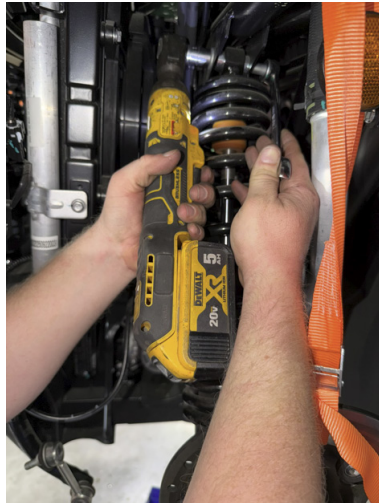
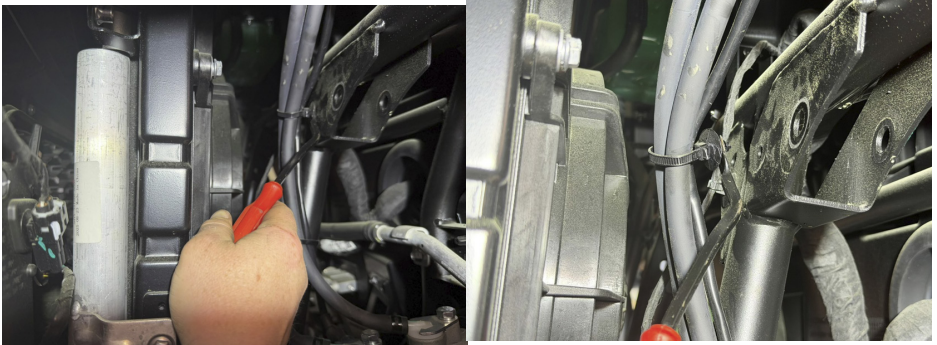

**FIG 20 - Remove the front shocks from the vehicle**

# INSTALLATION INSTRUCTIONS

## Front Installation

Prepare the front frame section for front shock relocation bracket installation by using a flathead screwdriver or similar tool to disconnect the master cylinder fill hoses from the frame. Repeat the process for disconnecting the wiring harness secured to the frame on the passenger side of the vehicle (**FIG 21 & FIG 22**).



**FIG 21 & FIG 22 - Disconnect master cylinder fill hoses from the frame**

Insert the front shock relocation brackets into place across the OEM shock mounts. Starting with the front side of the vehicle, use 2 x M12x80mm flange head bolts to hold the brackets in place. Slide the front shock spacer in place of the OEM shock mount. Once the second front shock relocation bracket is in place, cap off with an M12 flange nylon lock nut. Tighten using a 16mm socket and a 19mm wrench (**FIG 23**).

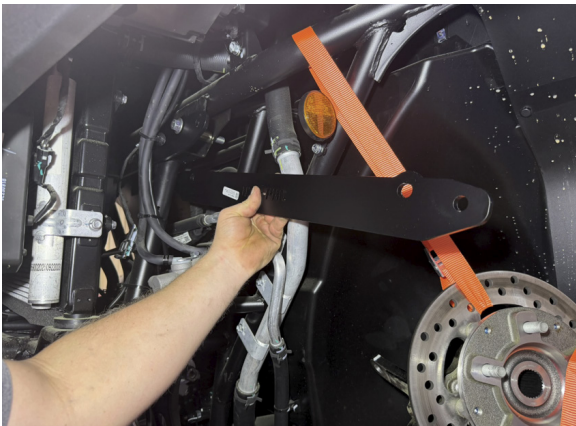
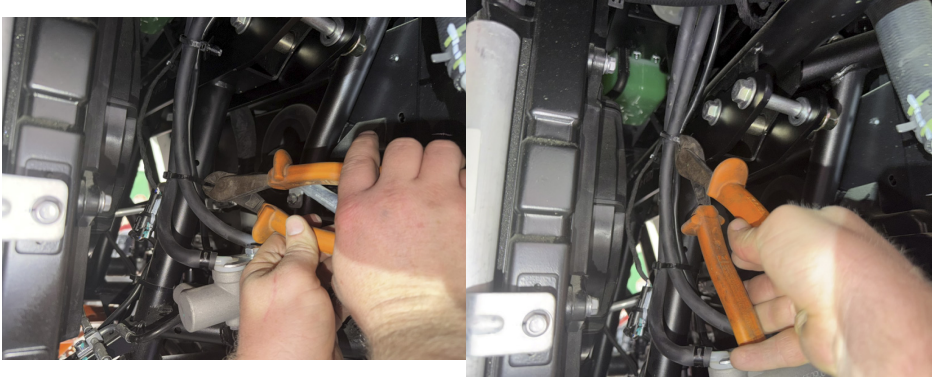

**FIG 23 - Mount Front Shock Relocation Brackets to the frame**

# INSTALLATION INSTRUCTIONS

## Front Installation

Use a pair of snips to cut the zip ties that hold the master cylinder fill hoses to the brake fluid pressure switch. This will be found in the front drivers wheel well near where the front shock relocation brackets were just installed (**FIG 24 & FIG 25**).



**FIG 24 & FIG 25 - Cut zip ties fastening master cylinder fill hoses to brake fluid pressure sensor wiring harness**

Disconnect the electrical connector under the hood located near the brake fluid reservoir under the hood shown below. Feed the brake fluid pressure sensor harness down to the drivers side wheel well through the hole provided in the underhood plastic near the brake fluid reservoir (**FIG 26 & FIG 27**).

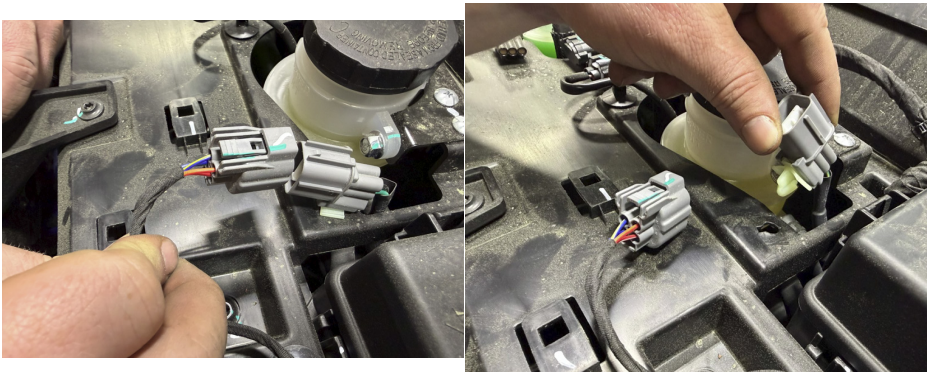
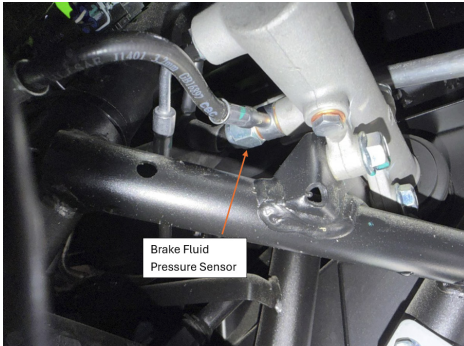

**FIG 26 & FIG 27 - Disconnect brake pressure sensor harness**

# INSTALLATION INSTRUCTIONS

## Front Installation

Using a 17mm wrench, unscrew the brake fluid pressure switch from the rear port of the master cylinder. This port sends fluid to your front brake calipers, be careful when unscrewing the brake sensor that the wiring harness connected to sensor does not get twisted or caught up in the frame (**FIG 28 & FIG 29**).



**FIG 28 & FIG 29 - Remove brake fluid pressure sensor**

Save the crush washers from the sensor, there will be one both side of the front brake feed line that was connected to the master cylinder (**FIG 30 & FIG 31**).

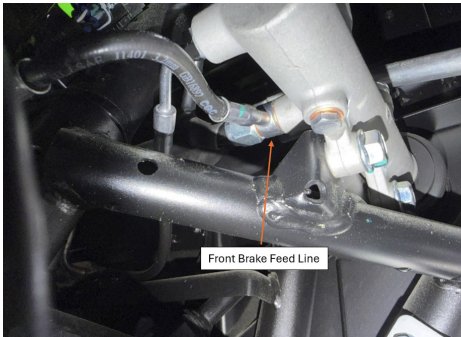

**FIG 30 & FIG 31 - Disconnect brake pressure sensor harness**

# INSTALLATION INSTRUCTIONS

## Front Installation

Using a 4mm allen wrench to remove the socket cap screw that fastens the front brake line junction block to the frame. Break the rivet holding the front passenger brake line to the frame located in a similar spot on the passenger side of the frame. Remove the front brake line assembly from the vehicle (**FIG 32**).



**FIG 32 - Remove the OEM front brake lines**

Thread the brake lines onto the new junction block supplied in the long travel kit. Tighten using a 12mm wrench (**FIG 33 & FIG 34**).



**FIG 33 & FIG 34 - Assemble new brake line junction block**

# INSTALLATION INSTRUCTIONS

## Front Installation

Slide the brake fluid pressure sensor through the new master cylinder line. Be sure to use crush washers on both sides of the new master cylinder brake line to prevent any leaks (**FIG 35**).



**FIG 35 - Insert brake sensor through new master cylinder brake line**

Thread the brake sensor into the master cylinder to fasten the new master cylinder brake line to the master cylinder. Tighten using a 17mm wrench, do not over tighten as it may strip the threads on the master cylinder (**FIG 36 & FIG 37**).

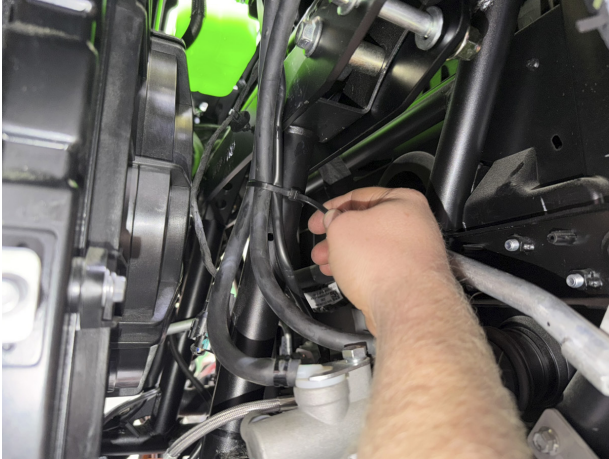

**FIG 36 & FIG 37 - Fasten the new brake lines to master cylinder**

# INSTALLATION INSTRUCTIONS

## Front Installation

Reroute the brake fluid pressure sensor harness to the hood and plug into the electrical connector. Zip tie the harness and brake fluid reservoir lines to the frame (**FIG 38**).



**FIG 38 - Reconnect brake sensor wiring harness**

Fasten the new brake junction block to the frame using a zip tie (**FIG 39**).

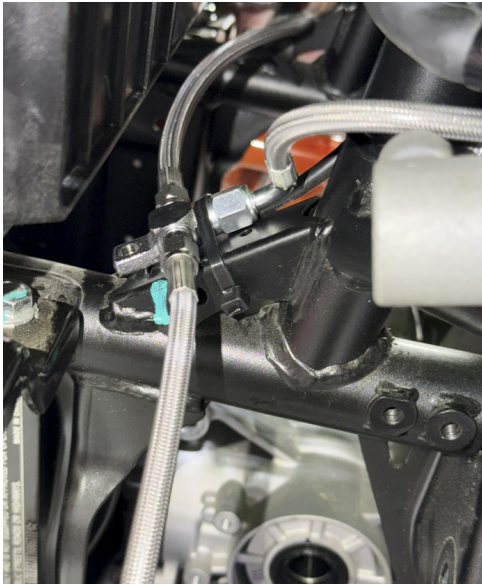

**FIG 39 - Fasten the new brake line junction block to the frame**

# INSTALLATION INSTRUCTIONS

## Front Installation

Fasten the front passenger brake line to the frame using a zip tie (**FIG 40**).



**FIG 40 - Fasten the passenger brake line to the frame**

Use a hammer and a long flathead screwdriver to break the clamp that fastens the OEM steering boot to the steering rack. Slide the steering boot back to gain access to the inner tie rod end (**FIG 41 & FIG 42**).

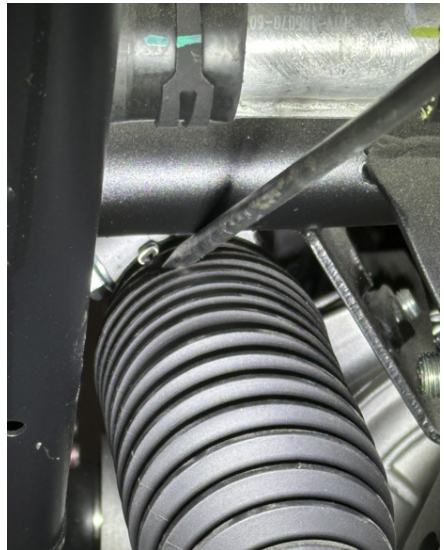
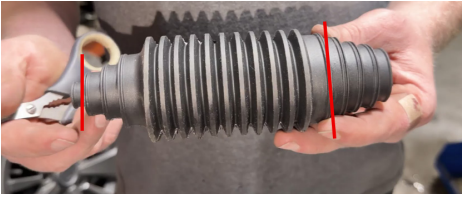

**FIG 41 & FIG 42 - Remove OEM steering boot clamp**

# INSTALLATION INSTRUCTIONS

## Front Installation

Remove the OEM tie rods by gripping the inner tie rod end with a large pair of channel locks. Trim the new steering boot in the following places to prepare for installation (**FIG 43 & FIG 44**).



**FIG 43 & FIG 44 - Trim the steering boot**

Here is what the steering boot should look like after the trimming is complete (**FIG 45**).

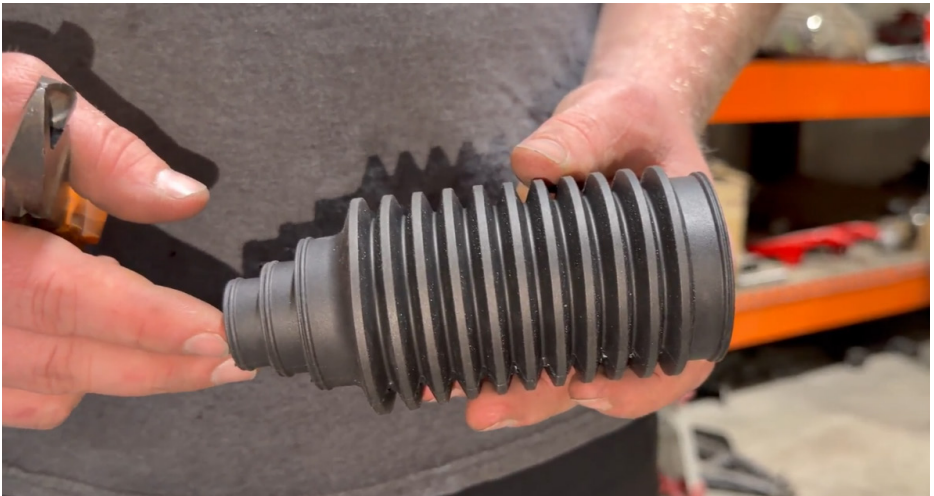
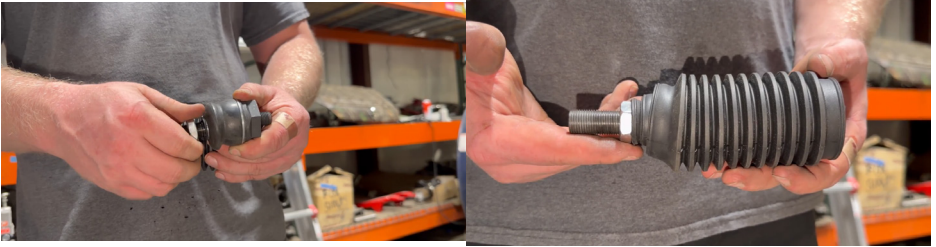

**FIG 45 - Steering boot (Trimmed)**

# INSTALLATION INSTRUCTIONS

## Front Installation

Remove the jam nut on the long threaded shank of the new inner tie rod and set aside. Slide the long shank of the inner tie rod through the steering boot and rethread the jam nut onto the inner tie rod to hold the boot in place (**FIG 46 & FIG 47**).



**FIG 46 & FIG 47 - Insert the inner tie rod into the steering boot**

Apply blue loctite to the threads of the inner tie rod that will thread into the steering rack (short shank) (**FIG 48**).



**FIG 48 - Apply loctite to the inner tie rod**

# INSTALLATION INSTRUCTIONS

## Front Installation

Install a steering stop on the worm gear of the steering rack (FIG 49).



**FIG 49 - Install Steering Stops**

Slide the hose clamps over the large side of the steering boot (FIG 50).

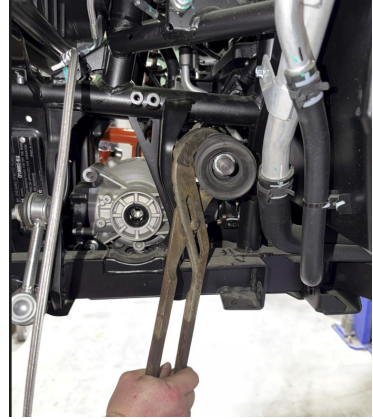

**FIG 50 - Slide hose clamp over steering boot**

# INSTALLATION INSTRUCTIONS

## Front Installation

Thread the inner tie rod assembly into the steering rack. Tighten using a large pair of channel locks. Once tight, slide the steering boot over the steering rack and secure using the hose clamp (**FIG 51 & FIG 52**).



**FIG 51 & FIG 52 - Install Inner Tie Rod**

Thread the tie rod assembly onto the inner tie rod (**FIG 53**).

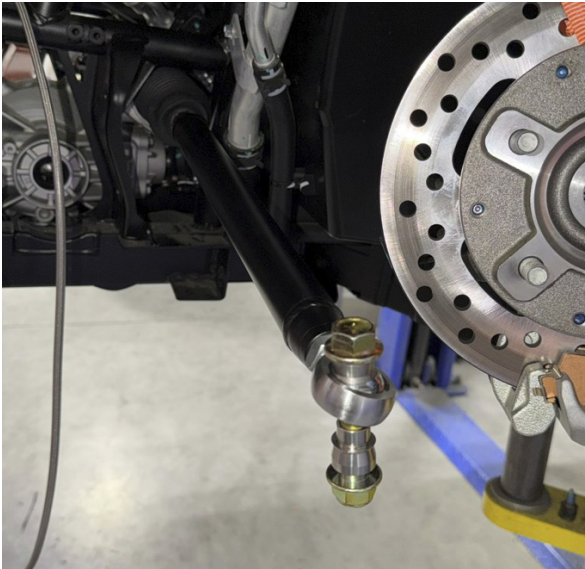

**FIG 53 - Install tie rod**

# INSTALLATION INSTRUCTIONS

## Front Installation

Fasten the front lower control arm to the vehicle using the OEM hardware, do not fully tighten at this time (**FIG 54**).



**FIG 54 - Mount lower control arm**

Apply anti-sieze to the axle and install in the differential (**FIG 55 & FIG 56**).



**FIG 55 & FIG 56 - Install front axles**

# INSTALLATION INSTRUCTIONS

## Front Installation

Slide the knuckle over the axle shaft and fasten the knuckle to the lower ball joint and tighten using a 19mm wrench (**FIG 57 & FIG 58**).



**FIG 57 & FIG 58 - Fasten the knuckle to the lower ball joint**

Fasten the upper control arm to the frame, do not fully tighten. Additionally fasten the sway bar end link to the upper control arm (**FIG 59 & FIG 60**).

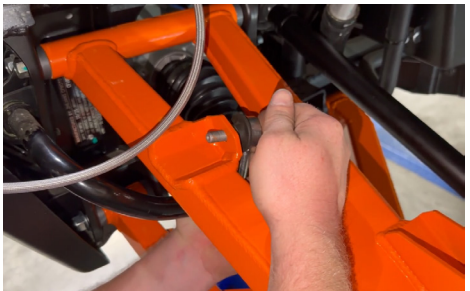
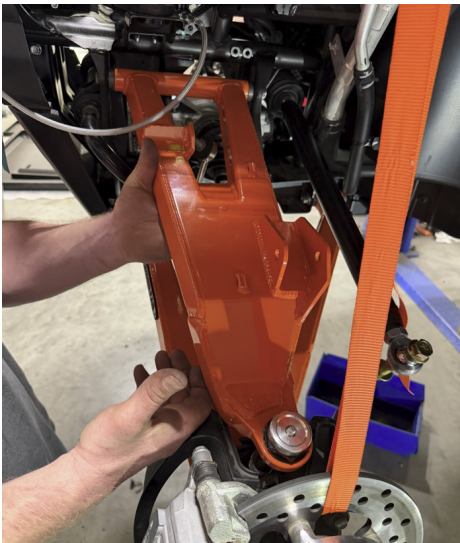

**FIG 59 & FIG 60 - Install upper control arm**

# INSTALLATION INSTRUCTIONS

## Front Installation

Fasten the upper ball joint to the knuckle, tighten using a 19mm wrench (**FIG 61**).



**FIG 61 - Fasten the knuckle to the upper ball joint**

Install the thick washer and the castle nut that fastens the axle to the knuckle assembly. Tighten using a 30mm socket (**FIG 62 & FIG 63**).



**FIG 62 & FIG 63 - Install and tighten front axle nut**

# INSTALLATION INSTRUCTIONS

## Front Installation

Use a cotter pin to keep the castle nut from backing off the axle (FIG 64).

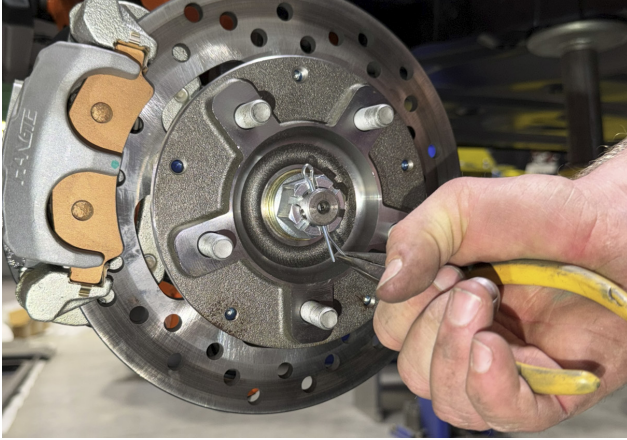

FIG 64 - Insert cotter pin into axle nut

Fasten the shock to the shock relocation brackets using the M12x80mm flange head bolts, M12 flange nylon lock nuts, and 1 x M12 flat washer located on the rear side of the shock eye (FIG 65 & FIG 66).



FIG 65 & FIG 66 - Install front shock

# INSTALLATION INSTRUCTIONS

## Front Installation

Slide the tapered end of the tie rod misalignment into the knuckle and fasten the tie rod to the knuckle (**FIG 67**).



**FIG 67 - Fasten the tie rod to the knuckle**

Fasten the shock to the upper control arm (**FIG 68**).

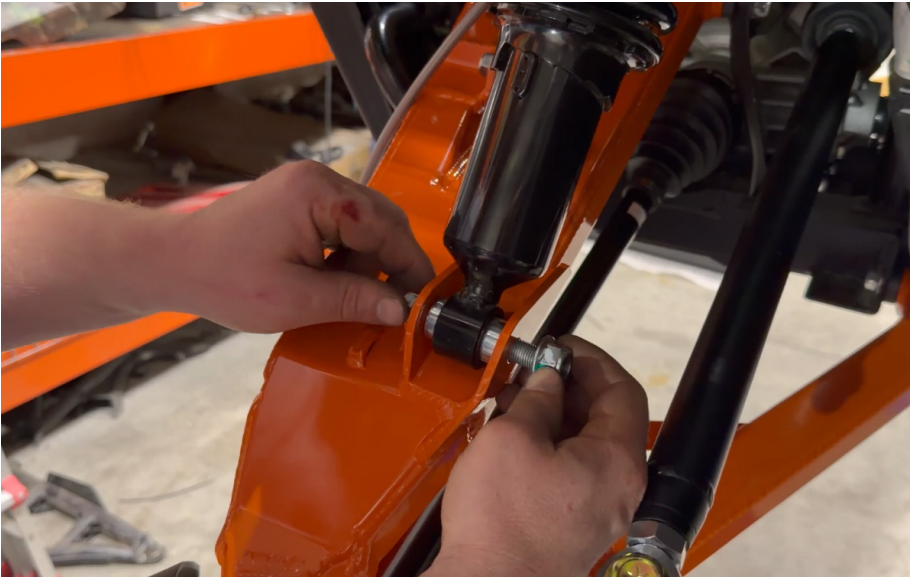

**FIG 68 - Fasten the shock to the upper control arm**

# INSTALLATION INSTRUCTIONS

## Rear Installation Preparation

Remove the rear axle cotter pins and axle nuts (**FIG 69 & FIG 70**).



**FIG 69 & FIG 70 - Remove the rear axle nuts**

Disconnect the sway bar from the rear lower control arm using a 15mm socket and an 18mm wrench (**FIG 71**).

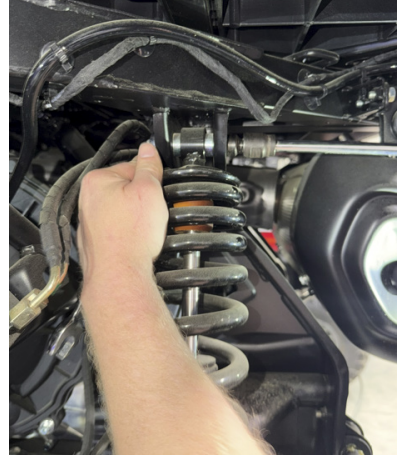
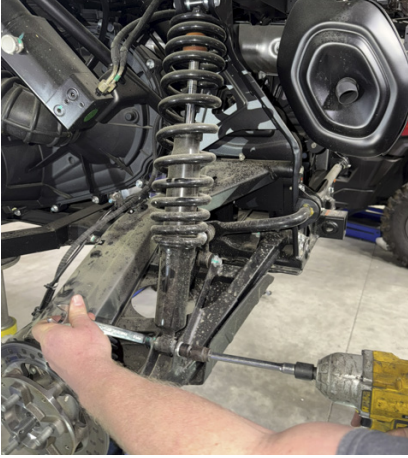

**FIG 71 - Disconnect the rear sway bar from the lower control arm**

# INSTALLATION INSTRUCTIONS

## Rear Installation Preparation

Remove the rear shock by disconnecting it from the lower control arm, then the frame mount. Once removed, set aside to be reinstalled in a later step (**FIG 72 & FIG 73**).



**FIG 72 & FIG 73 - Remove the rear shocks**

Remove the upper control arm knuckle mounting bolt (**FIG 74 & FIG 75**).

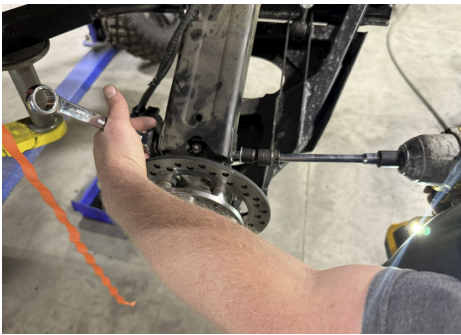
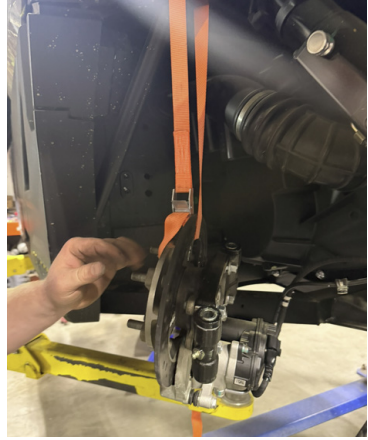

**FIG 74 & FIG 75 - Disconnect the upper control arm from the knuckle**

# INSTALLATION INSTRUCTIONS

## Rear Installation Preparation

**Do not disconnect the rear brake lines or attempt to remove the rear brake caliper from the knuckle.** Remove the lower control arm knuckle mounting bolt and tie the knuckle up to the side (FIG 76 & FIG 77).



**FIG 76 & FIG 77 - Remove the lower knuckle mounting bolt and tie the knuckle out of the way**

Remove the upper control arm frame mounting bolt and set the arm aside (FIG 78).

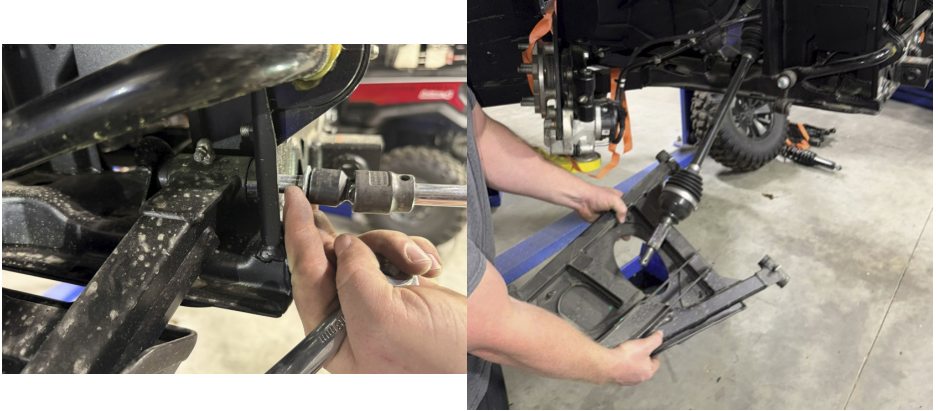

**FIG 78 - Remove the upper control arm**

# INSTALLATION INSTRUCTIONS

## Rear Installation Preparation

Remove the lower control arm frame mounting bolts and set the lower control arm aside. Remove the OEM axles from the rear differential (**FIG 79 & FIG 80**).



**FIG 79 & FIG 80 - Remove the lower control arm and rear axle**

Create slack in the rear brake lines by removing the fasteners that hold the rear brake lines to the outer rear frame sections (**FIG 81 & FIG 82**).

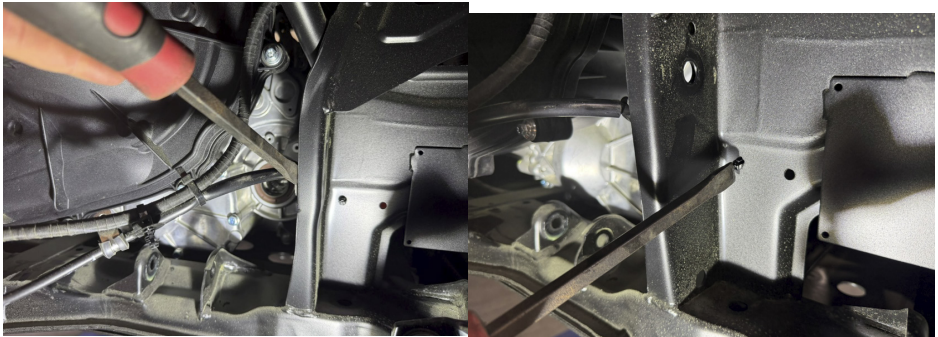

**FIG 81 & FIG 82 - Create slack in the rear brake lines**

# INSTALLATION INSTRUCTIONS

## Rear Installation Preparation

Insert the rear shock spacers in the rear shock relocation brackets to prepare for installation into the frame (FIG 83 & FIG 84).



**FIG 83 & FIG 84 - Insert the rear shock spacers into the rear shock relocation brackets**

Fasten the rear shock relocation brackets to the rear frame section using the OEM shock mounting hardware. Do not tighten at this time (FIG 85 & FIG 86).

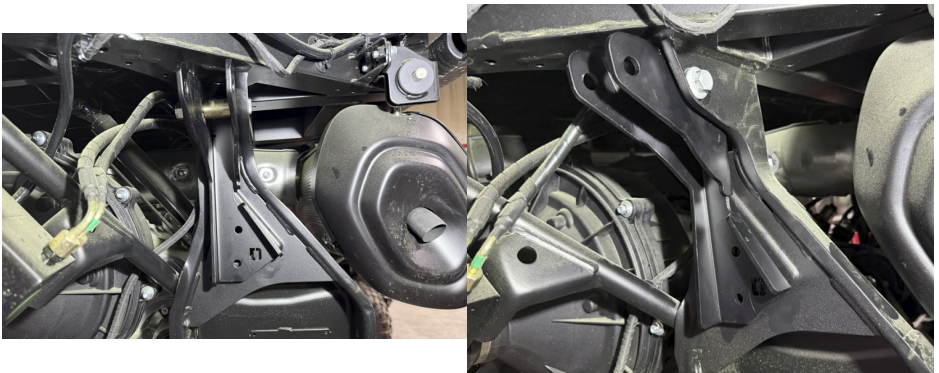

**FIG 85 & FIG 86 - Loosely mount the rear shock relocation brackets**

# INSTALLATION INSTRUCTIONS

## Rear Installation

Insert the rear shock relocation sandwich plates into the frame and fasten the rear shock relocation brackets to the sandwich plates using 2 x M8x25mm flange head bolts and 2 x M8 flange nylon lock nuts. Tighten using a 13mm socket and 13mm wrench (**FIG 87 & FIG 88**).



**FIG 87 & FIG 88 - Fasten the Rear Shock Relocation Sandwich Plates to the frame and the Rear Shock Relocation Brackets**

Tighten the remaining mount bolt using a 15mm socket and 18mm wrench (**FIG 89**).



**FIG 89 - Fully tighten the Rear Shock Relocation Bracket**

# INSTALLATION INSTRUCTIONS

## Rear Installation

Loosley fasten the rear lower control arm to the vehicle using the OEM hardware (**FIG 90**).



**FIG 90 - Fasten the rear lower arm to the frame**

Fasten the rear sway bar end link to the lower arm (**FIG 91**).

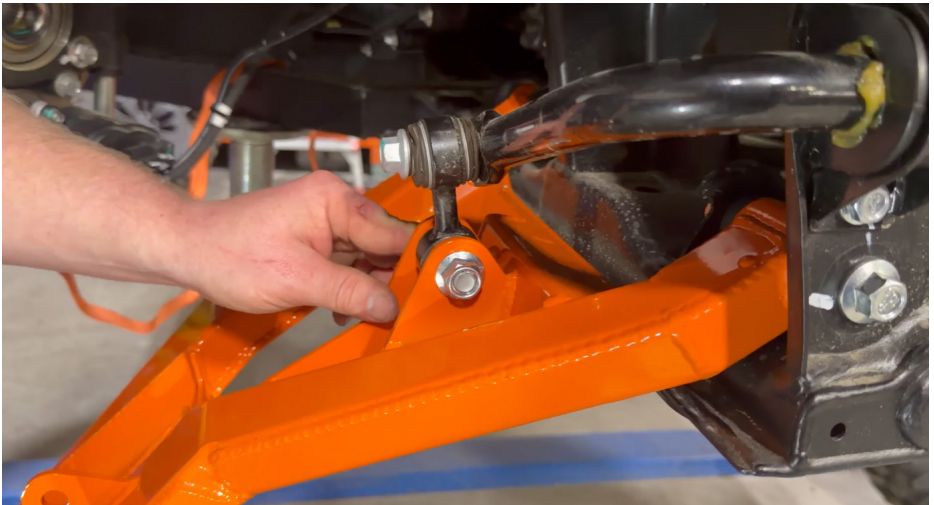

**FIG 91 - Fasten Sway Bar to lower arm**

# INSTALLATION INSTRUCTIONS

## Rear Installation

Apply anti-sieze to the rear axle and install it into the rear differential (FIG 92).



FIG 92 - Insert rear axles

Slide the knuckle over the axle and fasten the knuckle to the lower control arm using the OEM hardware (FIG 93 & FIG 94).

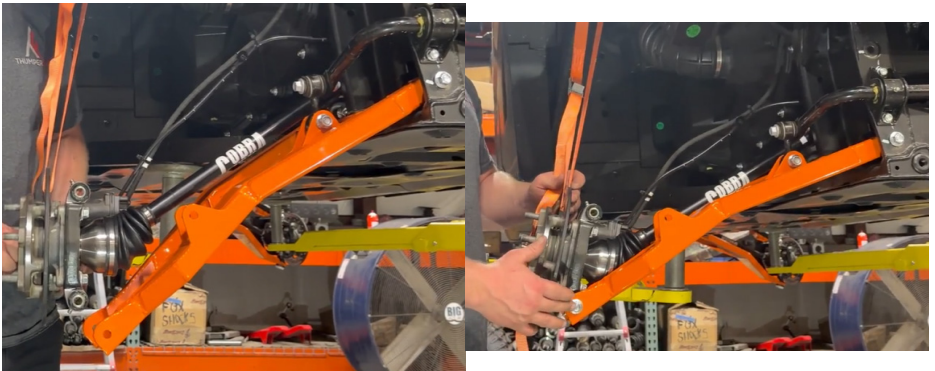

FIG 93 & FIG 94 - Fasten Knuckle to lower control arm

# INSTALLATION INSTRUCTIONS

## Rear Installation

If additional slack in brake lines are needed, disconnect the brake line and parking brake harnesses from further frame connection points (**FIG 95**).



**FIG 95 - Create extra brake line slack if needed**

Loosley fasten the upper control arm to the frame (**FIG 96**).



**FIG 96 - Fasten the upper control arm to the frame**

## INSTALLATION INSTRUCTIONS

### Rear Installation

Fasten the upper eye of the rear shock to the shock relocation bracket using the M12x70mm flange head bolts and M12 flange nylon lock nuts (**FIG 97**).



**FIG 97 - Fasten rear shock to relocation brackets**

Fasten the upper control arm to the knuckle using the OEM hardware (**FIG 98**).

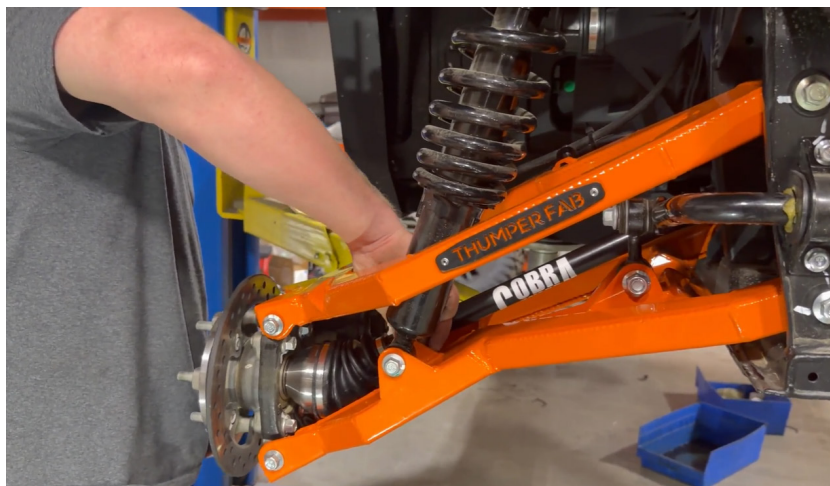

**FIG 98 - Fasten the upper control arm to the knuckle**

# INSTALLATION INSTRUCTIONS

## Rear Installation

Fasten the rear shock to the lower control arm (**FIG 99**).



**FIG 99 - Fasten rear shock to the lower control arm**

Install the thick flat washer and axle nut back on the axle shaft and tighten using a 30mm socket (**FIG 100 & FIG 101**).



**FIG 100 & FIG 101 - Install and tighten the axle nut**

# INSTALLATION INSTRUCTIONS

## Rear Installation

Install a cotter pin in the rear axle castle nut to prevent the nut from loosening (**FIG 102**).



**FIG 102 - Install cotter pin in rear axle nut**

Fasten the rear brake lines and parking brake harness to the upper control arm using zip ties (**FIG 103 & FIG 104**).



**FIG 103 & FIG 104 - Fasten brake lines to rear upper control arm**

# INSTALLATION INSTRUCTIONS

## Rear Installation

Fasten the brake lines to the front upper control arm using zip ties (**FIG 105**).



**FIG 105 - Fasten front brake lines to control arms**

Mount the wheels and lower the vehicle to the ground, bleed the brakes, tighten any remaining loose hardware and adjust the toe as needed. Enjoy your new Thumper Fab U10 Long Travel Kit!



# INSTALLATION INSTRUCTIONS

## PRODUCT DISCLAIMER

The installation of products sold or manufactured by Thumper Fabrication, LLC (Thumper Fab) including, but not limited to suspension components such as lift kits, audio roofs, roll cages, frame stiffener kits, and tires that exceed the original specifications for the vehicle, may change the vehicle's center of gravity and handling characteristics both on- and off-road. You are aware that the installation of tires that are larger than original vehicle specifications may reduce the effectiveness of the braking system. Use of these products may place added stress to the original factory vehicle components which could cause them to weaken or possibly fail.

Products sold or manufactured by Thumper Fab are intended for off-road use only. Operation of a vehicle modified with these products on a road could result in serious bodily injury or death, and such operation may violate the laws of your state or municipality. You agree to operate your vehicle exclusively in the manner intended by the vehicle manufacturer. You agree that failure to safely and reasonably operate your vehicle could result in serious bodily injury or death, and that, as a result of installation of this product(s) to your vehicle, extreme care must be taken to prevent vehicle rollover or loss of control, which may be more likely to occur as a result of said modifications. You will avoid unsafe maneuvers, including sudden sharp turns or other abrupt maneuvers, which could make a vehicular accident more likely. You understand that Thumper Fab is not responsible or liable for any damages or any injuries to yourself or your passengers that could occur upon possible accidents due to driver error, incorrect installations, bad judgment, incompatibility with other aftermarket accessories or natural disasters to the fullest extent allowable by law. You will have all vehicle occupants fasten seatbelts, if equipped, and wear proper safety equipment, such as DOT approved helmet and eye protection prior to operating the vehicle. You understand and acknowledge that failure to wear proper safety equipment may increase the risk of serious bodily injury or death to yourself and any passengers.

Proper installation of products sold or manufactured by Thumper Fab requires knowledge of the factory recommended procedures for removal and installation of original equipment components. Installation of these products without proper knowledge and experience may affect the performance of these components and the safety of the vehicle and cause serious bodily injury or death. It is strongly recommended that a certified mechanic familiar with the installation of similar components perform the product(s) installation.

Prior to installing any products sold or manufactured by Thumper Fab, you will perform or cause to be performed an inspection of their vehicle to confirm its condition is suitable for the installation of these products. A proper inspection of the vehicle includes confirmation that the vehicle has not been in a collision and is free of corrosion. If the vehicle is suspected to have been in a collision or misused, or is otherwise unsuitable for modification, you will not install the product(s). You will continue to inspect the vehicle prior to each use to confirm its condition is suitable for its intended use, and you acknowledge that the failure to do so may result in serious bodily injury or death, as well as damage to the vehicle itself.

You will install any warning labels provided with the product so it may be prominently seen by yourself and all passengers. You will notify all passengers of the modifications performed to your vehicle prior to operation.

Insurance companies may handle coverage of a modified vehicle differently. Please check with your insurance carrier prior to modifying the vehicle to ensure your coverage remains sufficient. Installation of this product(s) may void your vehicle warranty. If this is a concern, please check with the manufacturer or dealer before purchase or installation of this product(s).



**THUMPER FAB**

**Thumper Fab**

5103 Elysian Fields Rd, Marshall, TX 75672

Customer Service: 903-472-0928

[www.thumperfab.com](http://www.thumperfab.com)