

Polaris Ranger 1500XD
Rear Winch Bumper

SKU: TF230601



Thumper Fab

5103 Elysian Fields Rd, Marshall, TX 75672
Customer Service: 903-472-0928

Polaris Ranger 1500XD

Rear Winch Bumper

SKU: TF230601



PARTS

REF	QTY	DESCRIPTION
1	1	Rear Winch Bumper - Main Body
2	1	Mount Bracket - DRIVER
3	1	Mount Bracket - PASSENGER
4	1	Light Cover - DRIVER
5	1	Light Cover - PASSENGER

TOOLS

- 13mm Socket or Wrench
- 10mm Socket or Wrench
- 15/64" Socket or Wrench
- 9/16" Socket or Wrench
- 9/64" Allen
- 7/32" Allen
- 6mm Allen

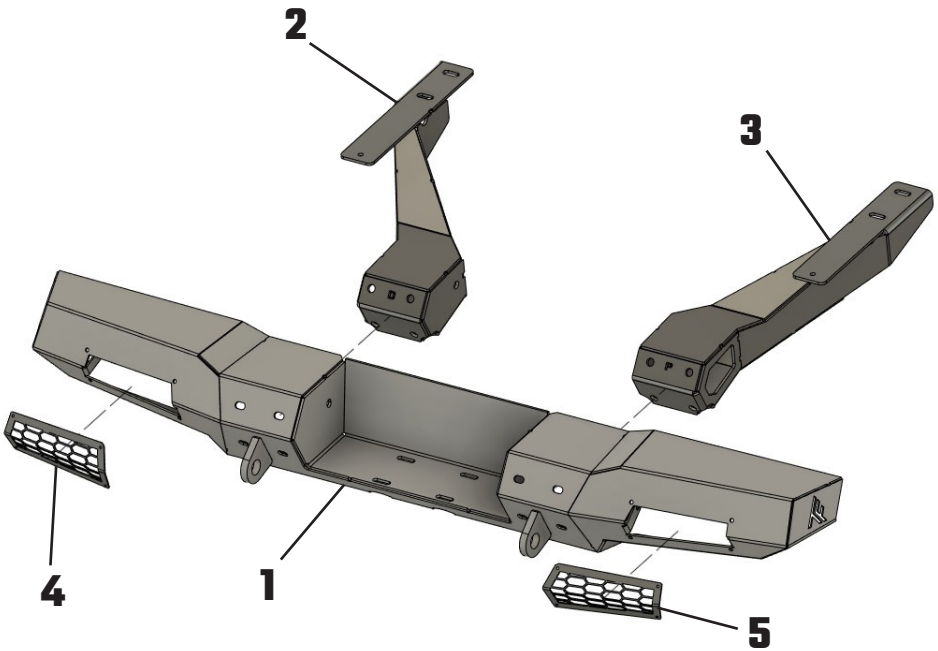

BEFORE YOU BEGIN

If you do not feel comfortable installing your Thumper Fab Rear Winch Bumper, please see your nearest Polaris® Dealer for installation.

INSTALLATION INSTRUCTIONS

HARDWARE

REF	QTY	DESCRIPTION
A	10	3/8"-16 Button Head Screw
B	10	3/8" Stainless Flat Washer
C	10	3/8"-16 Nylon Locknut
D	8	#8-32 x 1/2" Socket Cap Screw
E	8	#8-32 Locknut
F	2	M8 x 70mm Button Head Bolt
G	2	M8 Flat Washer
H	2	M8 Flanged Locknut
I	2	Threaded Rubber Bumper

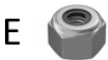

INSTALLATION INSTRUCTIONS

Removing OEM Bed Hinge Clamps

First, start by removing both bed hinge clamps using a 13mm socket/wrench. Remove the locknuts, remove the clamps, and set them to the side (**FIG 1**).

FIG 1



Install the Mount Brackets

Next, you will need to lift the bed up slightly using the bed actuator and by lifting the rear end of the bed by hand. The bed needs to be lifted just enough to slip the mount bracket upward onto the threaded studs and over the bed hinge cylinder (**FIG 2**).

FIG 2



INSTALLATION INSTRUCTIONS

Re-install OEM Bed Hinge Clamps

After both mount brackets have been installed into place, re-install the bed hinge clamp and oem locknuts that were previously removed. **DO NOT** fully tighten these bolts yet. Take up as much slack in them as possible, but the mounts need to remain slightly loose until installation is complete (**FIG 3**).

FIG 3

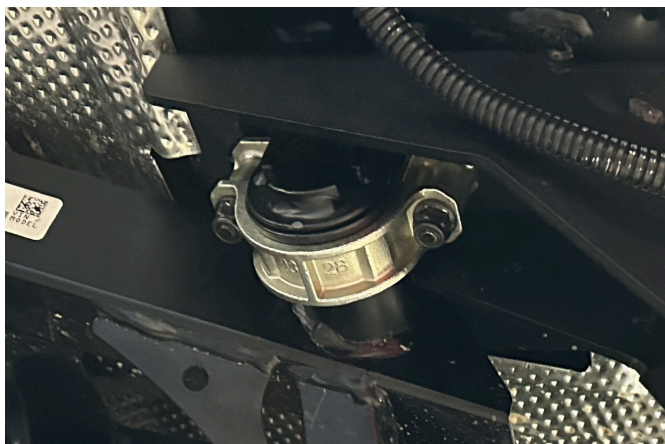

Installing Main Bumper Body

Fasten the lights to the bumper body using hardware and tools provided in the light bar box, if light option was selected (**FIG 4**) Mount the light bar covers using 8 x #8-32 x1/2" socket cap screws and 8 x #8-32 nylon lock nuts (**FIG 5**).



FIG 4

FIG 5

INSTALLATION INSTRUCTIONS

Installing Main Bumper Body

Lift the main bumper body up into place by placing it over the ends of both rear mount brackets. Loosely fasten it with the (10) 3/8" Button Head Bolts, M8 washers, and M8 locknuts (**FIG 6**)

FIG 6

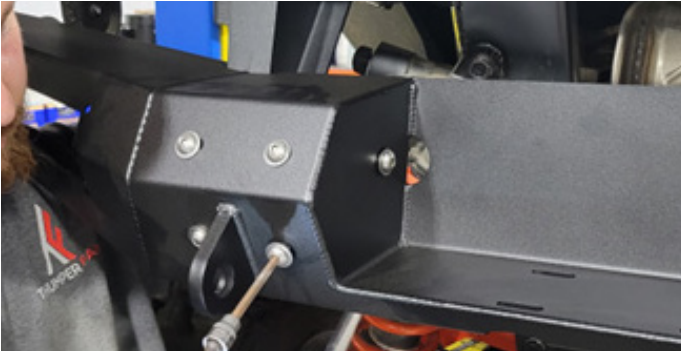

Drilling Through Bed

After the mount brackets and main bumper body have been installed, loosely, you will then need to drill through the bed, using the open holes on the mount brackets and a template. (**FIG 7 & FIG 8**)

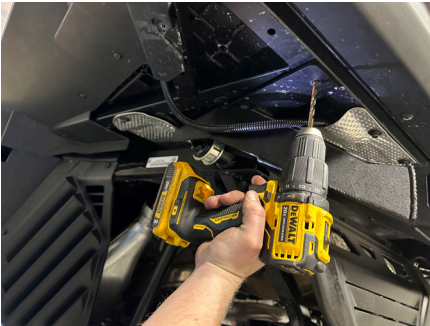

FIG 7



FIG 8

INSTALLATION INSTRUCTIONS

Next, run the M8 x 70mm bolts down through the top of the bed and then fasten with the M8 washer and M8 locknut.

After both bolts have been installed and make sure bed is pulled rearward as much as possible, start with the first oem locknuts that you removed first, then working through all hardware in the assembly. Tighten all hardware.

Install Rubber Threaded Bumpers

Remove the (2) lower M6 Screws that fasten the exhaust shield onto the unit using a 10mm socket. Thread the rubber bumper into holes in frame and tighten by hand. These bumpers will help stop the bumper when dumping the bed with the electric lift (**FIG 9 & FIG 10**).



FIG 9



FIG 10

INSTALLATION INSTRUCTIONS

Light Wiring (OPTIONAL)

Breakdown of wiring harness supplied with light option is shown below (FIG 11).

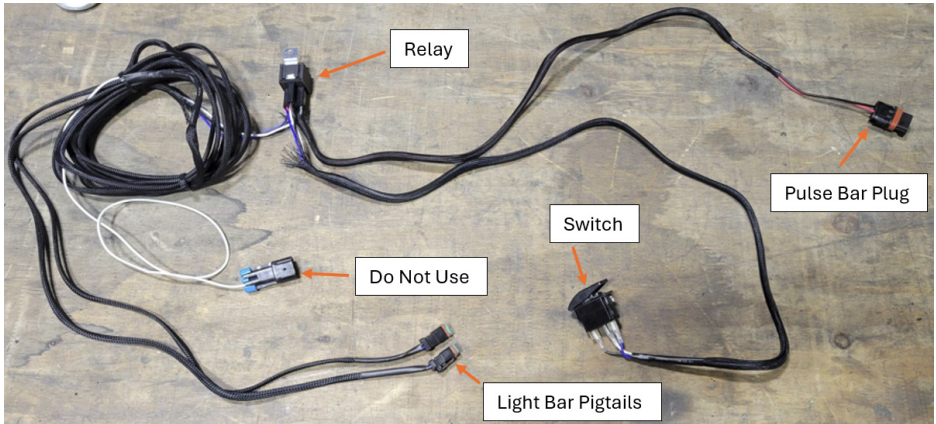

FIG 11 - Wiring Harness Breakdown

Plug the harness into the light bars mounted in the bumper and route wiring towards the front of the vehicle. Be sure to avoid any spinning or hot components that may cause damage to the harness (FIG 12).



FIG 12 - Plug in Light Pigtails

INSTALLATION INSTRUCTIONS

Light Wiring (OPTIONAL)

Route the wiring into hood compartment and plug the pulse bar plug into an open slot on the pulse bar (**FIG 13**).

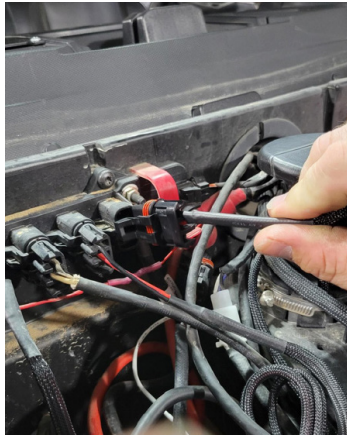

FIG 13 - Plug in Pulse Bar Plug

Route switch wiring through the firewall and select open slot in dash to run the wires through before connecting wires to switch with blue wire on top, white wire in the middle, and black wire on the bottom terminal and install switch into slot in dash (**FIG 14 & FIG 15**).

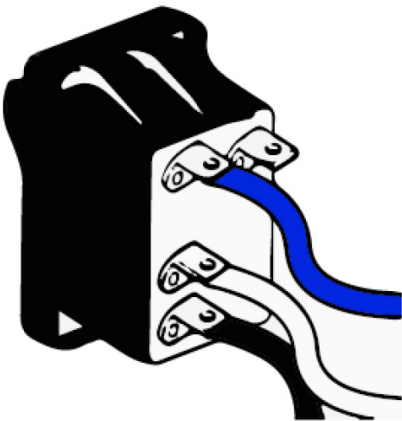

FIG 14 & FIG 15 - Wire Switch and Install in Dash

INSTALLATION INSTRUCTIONS

The installation of products sold or manufactured by Thumper Fab including, but not limited to suspension components such as lift kits, control arms, frame stiffener kits, roofs, roll cages, and tires that exceed the original specifications for the vehicle, may change the vehicle's center of gravity and handling characteristics both on- and off-road. You are aware that the installation of tires that are larger than original vehicle specifications may reduce the effectiveness of the braking system. Use of these products may place added stress to the original factory vehicle components which could cause them to weaken or possibly fail.

Products sold or manufactured by Thumper Fab are intended for off-road use only. Operation of a vehicle modified with these products on a road could result in serious bodily injury or death, and such operation may violate the laws of your state or municipality. You agree to operate your vehicle exclusively in the manner intended by the vehicle manufacturer. You agree that failure to safely and reasonably operate your vehicle could result in serious bodily injury or death, and that, as a result of installation of this product(s) to your vehicle, extreme care must be taken to prevent vehicle rollover or loss of control, which may be more likely to occur as a result of said modifications. You will avoid unsafe maneuvers, including sudden sharp turns or other abrupt maneuvers, which could make a vehicular accident more likely. You understand that Thumper Fab is not responsible or liable for any damages or any injuries to yourself or your passengers that could occur upon possible accidents due to driver error, incorrect installations, bad judgment, incompatibility with other aftermarket accessories or natural disasters to the fullest extent allowable by law. You will have all vehicle occupants fasten seatbelts, if equipped, and wear proper safety equipment, such as DOT approved helmet and eye protection prior to operating the vehicle. You understand and acknowledge that failure to wear proper safety equipment may increase the risk of serious bodily injury or death to yourself and any passengers.



THUMPER FAB

Thumper Fab

5103 Elysian Fields Rd, Marshall, TX 75672

Customer Service: 903-472-0928

www.thumperfab.com