



THUMPER FAB

Aluminum Audio Roofs ♦ Roll Cages ♦ UTV Accessories

Polaris Xpedition **Rear SPORT Bumper**

SKU: TF200602



Thumper Fab

5103 Elysian Fields Rd, Marshall, TX 75672

Customer Service: 903-472-0928

www.thumperfab.com

Ver. 0125

Polaris Xpedition

Rear SPORT Bumper

SKU: TF200602



PARTS

REF	QTY	DESCRIPTION
1	1	Main Bumper Body
2	1	Bumper Mount Bracket - DRIVER
3	1	Bumper Mount Bracket - PASSENGER
4	2	Bumper Mount Connector
5	1	Light Bar Cover - DRIVER
6	1	Light Bar Cover - PASSENGER
7	1	Logo Backing Plate
HARDWARE KIT		
A	2	1/8" Rivet
B	8	M8 x 20mm Flange Bolt
C	8	M8 Flanged Locknut
D	10	#8-32 x 1/2" Stainless Hex Head Screw
E	10	#8-32 Stainless Locknut

TOOLS

- 13mm Socket and Wrench
- T40 Torx
- 11/32" Socket or wrench
- 9/64" Allen
- Rivet tool

BEFORE YOU BEGIN

If you do not feel comfortable installing your **Thumper Fab** Rear Bumper, please see your nearest Polaris® Dealer for installation.

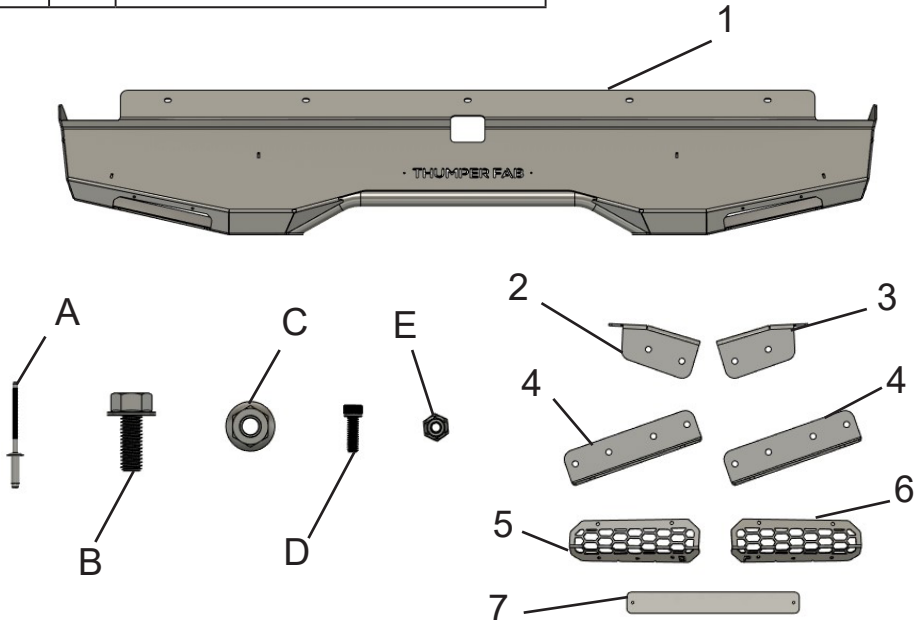

INSTALLATION INSTRUCTIONS

Pre-installing Light Covers, Etc.

First, start by pre-installing the light covers and light bars (if purchased with the kit). Use the #8-32 hardware for the covers and the provided hardware for the light bars. (FIG 1, 2, & 3).



FIG 1



FIG 2



FIG 3

INSTALLATION INSTRUCTIONS

Installation

Begin the installation by locating and removing the OEM M6 Torx Screws that fasten the heat shield along the bottom of the bed. Set these aside because they will be re-used later. See below. (FIG 4).



FIG 4

Next, remove the (6) OEM M8 bolts that fasten the bed to the OEM mount brackets. (3) bolts on each side. Shown below. (FIG 4).



FIG 5

INSTALLATION INSTRUCTIONS

Next, locate the Bumper Mount Brackets (driver and passenger). Mount on their correct sides, re-using the OEM M8 bolts previously removed. Shown below. (FIG 6).



FIG 6 (Driver side shown)

Next, lift the main bumper body up into place. Insert the rear edge of the bumper body in between the heat shield and the bed, then manipulate the bumper body into place so that the slots in the bumper align with the holes in the heat shield. Once aligned properly, replace the OEM M6 Torx screws that were previously removed. DO NOT tighten completely yet. See below. (FIG 7).



FIG 7

INSTALLATION INSTRUCTIONS

Installation

Next, locate the bumper mount connectors and install as shown using the M8 hardware provided in the kit. See below. (FIG 8).



FIG 8

After all hardware has been installed, you can then make any last fitment adjustments and then tighten all hardware completely.

OPTIONAL: Light Bar Wiring Harness

If you purchased the light bar option, next route the wiring harness from the light that pre-installed into the bumper to the pulse bar under the hood. Then route the pigtail for the switch through the rubber grommet in the firewall and to the switch position of your choice in the dash. (FIG 9).

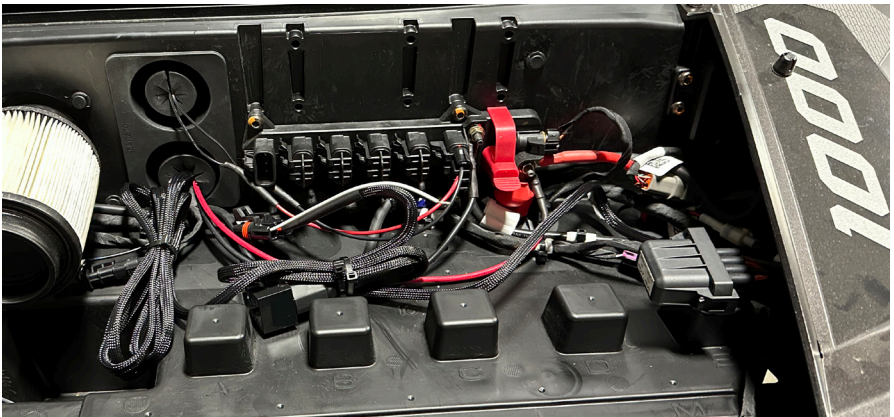

FIG 9

INSTALLATION INSTRUCTIONS

OPTIONAL: Light Bar Wiring Harness

The white wire shown below WILL NOT be used. This wire can be cut off and the end wrapped in electric tape. (FIG 9).

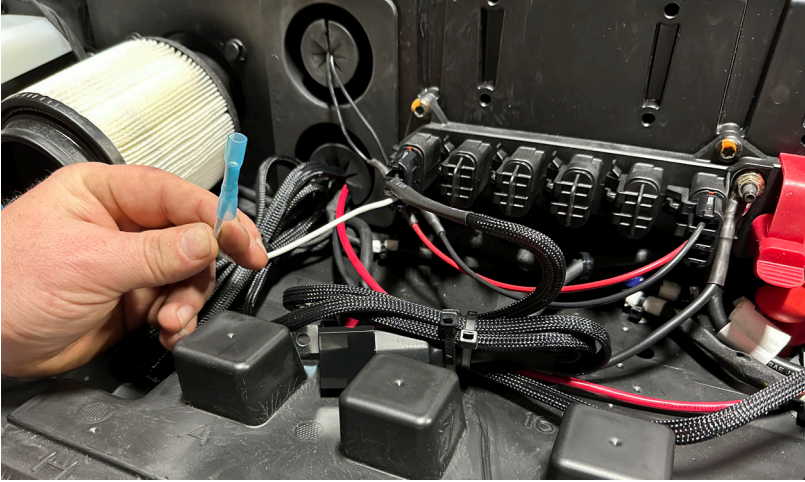

FIG 9

After the switch position has been chosen and the hole has been cut into the dash, wire the switch as shown below. (FIG. 10)

A-black
B-white
C-blue



FIG 10

INSTALLATION INSTRUCTIONS

PRODUCT DISCLAIMER

The installation of products sold or manufactured by Thumper Fabrication, LLC (Thumper Fab) including, but not limited to suspension components such as lift kits, audio roofs, roll cages, frame stiffener kits, and tires that exceed the original specifications for the vehicle, may change the vehicle's center of gravity and handling characteristics both on- and off-road. You are aware that the installation of tires that are larger than original vehicle specifications may reduce the effectiveness of the braking system. Use of these products may place added stress to the original factory vehicle components which could cause them to weaken or possibly fail.

Products sold or manufactured by Thumper Fab are intended for off-road use only. Operation of a vehicle modified with these products on a road could result in serious bodily injury or death, and such operation may violate the laws of your state or municipality. You agree to operate your vehicle exclusively in the manner intended by the vehicle manufacturer. You agree that failure to safely and reasonably operate your vehicle could result in serious bodily injury or death, and that, as a result of installation of this product(s) to your vehicle, extreme care must be taken to prevent vehicle rollover or loss of control, which may be more likely to occur as a result of said modifications. You will avoid unsafe maneuvers, including sudden sharp turns or other abrupt maneuvers, which could make a vehicular accident more likely. You understand that Thumper Fab is not responsible or liable for any damages or any injuries to yourself or your passengers that could occur upon possible accidents due to driver error, incorrect installations, bad judgment, incompatibility with other aftermarket accessories or natural disasters to the fullest extent allowable by law. You will have all vehicle occupants fasten seatbelts, if equipped, and wear proper safety equipment, such as DOT approved helmet and eye protection prior to operating the vehicle. You understand and acknowledge that failure to wear proper safety equipment may increase the risk of serious bodily injury or death to yourself and any passengers.

Proper installation of products sold or manufactured by Thumper Fab requires knowledge of the factory recommended procedures for removal and installation of original equipment components. Installation of these products without proper knowledge and experience may affect the performance of these components and the safety of the vehicle and cause serious bodily injury or death. It is strongly recommended that a certified mechanic familiar with the installation of similar components perform the product(s) installation.

Prior to installing any products sold or manufactured by Thumper Fab, you will perform or cause to be performed an inspection of their vehicle to confirm its condition is suitable for the installation of these products. A proper inspection of the vehicle includes confirmation that the vehicle has not been in a collision and is free of corrosion. If the vehicle is suspected to have been in a collision or misused, or is otherwise unsuitable for modification, you will not install the product(s). You will continue to inspect the vehicle prior to each use to confirm its condition is suitable for its intended use, and you acknowledge that the failure to do so may result in serious bodily injury or death, as well as damage to the vehicle itself.

You will install any warning labels provided with the product so it may be prominently seen by yourself and all passengers. You will notify all passengers of the modifications performed to your vehicle prior to operation.

Insurance companies may handle coverage of a modified vehicle differently. Please check with your insurance carrier prior to modifying the vehicle to ensure your coverage remains sufficient. Installation of this product(s) may void your vehicle warranty. If this is a concern, please check with the manufacturer or dealer before purchase or installation of this product(s).



THUMPER FAB

Thumper Fab

5103 Elysian Fields Rd, Marshall, TX 75672

Customer Service: 903-472-0928

www.thumperfab.com