



# THUMPER FAB

Aluminum Audio Roofs ♦ Roll Cages ♦ UTV Accessories

**Can-Am/Defender**

**Long Travel**

SKU: TF042001

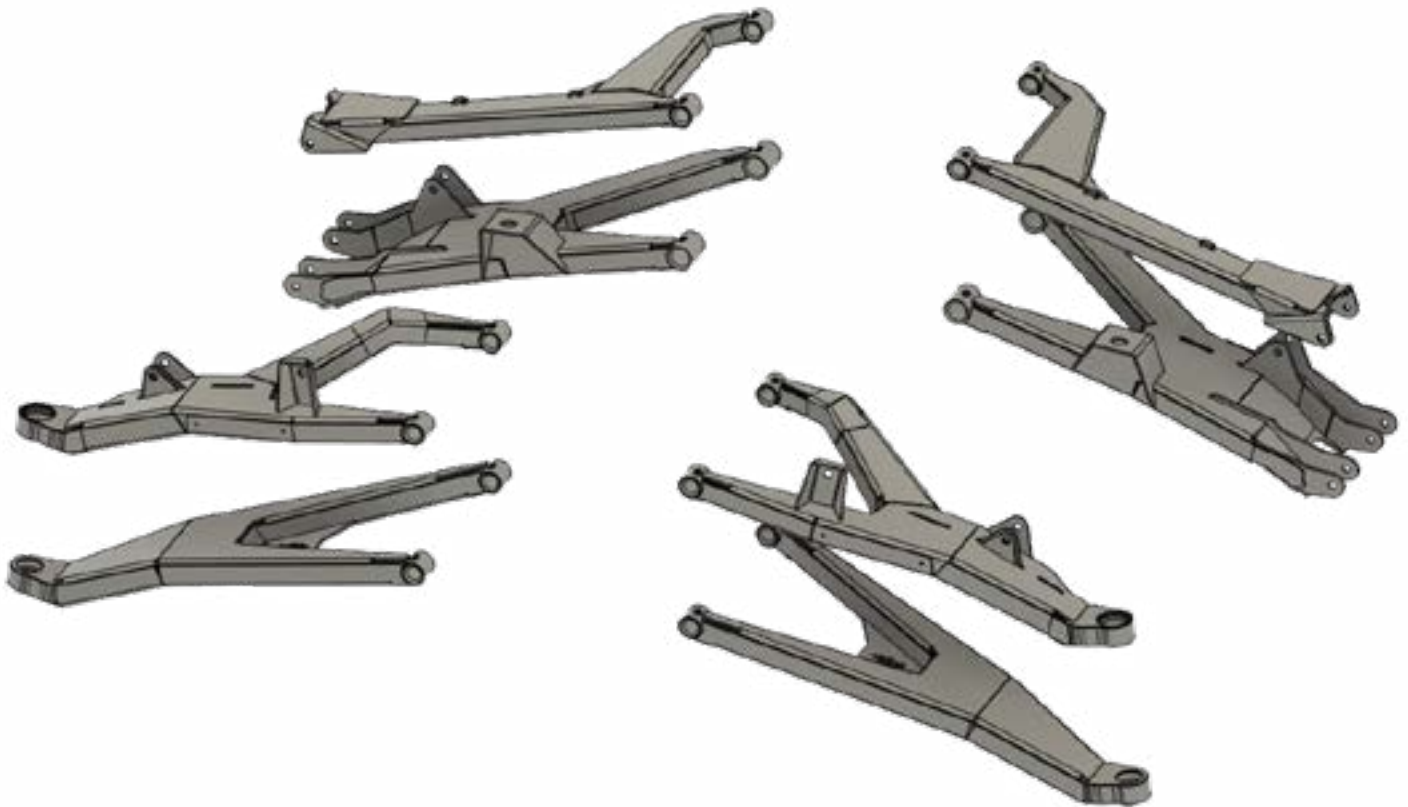

**Thumper Fab**

5103 Elysian Fields Rd, Marshall, TX 75672  
Customer Service: 903-472-0928

[www.thumperfab.com](http://www.thumperfab.com)

VER. 0325

# Can-Am/Defender

## Long Travel

SKU: TF042001



### PARTS

REF	QTY	DESCRIPTION
1	1	Driver Front Upper Arm
2	1	Driver Front Lower Arm
3	1	Driver Rear Upper Arm
4	1	Driver Rear Lower Arm
5	1	Passenger Front Upper Arm
6	1	Passenger Front Lower Arm
7	1	Passenger Rear Upper Arm
8	1	Passenger Rear Lower Arm
9	2*	TF Tie-Rod
10	2*	TF Elite Billet Tie-Rod
11	1	Brake Line Kit
12	4	Axles
13	4*	ZBroz Shocks
14	2*	OEM Shock Relocation Bracket Front
15	2*	OEM Shock Relocation Bracket Rear
HARDWARE KIT		
A	2	Kryptonite Inner Tie-Rod
B	2	Outer Tie-Rod Heim Joint
C	2	Outer Tie-Rod Jam Nut
D	4	Outer Tie-Rod Misalignment Spacer
E	2	Steering Stop
F	4*	Ball Joint Sleeve (OEM and Keller Only)
H	4	Uni-ball Snap Rings
I	4	Ball Joint Snap Rings
J	2	M10-1.5 x 110mm Bolt
K	6*	M10-1.5 x 60mm Bolt
L	4	M10-1.5 Nyloc Nut
M	24	Cable Ties
N	4*	M10-1.5 x 25mm Bolt (OE Shock Bracket)
O	8*	M10-1.5 Nyloc Nut (OE Shock Bracket)
P	4*	M10 Fender Washer (OE Shock Bracket)
Q	1	Ball Joint Press Tool
R	1	6 Inches of Wire Loom
*QTY depends on options selected		

### TOOLS

- 13mm Socket
- 15mm Socket
- 18mm Socket
- 19mm Socket
- 27mm Socket
- 11mm Wrench
- 12mm Wrench
- 13mm Wrench
- 15mm Wrench
- 18mm Wrench
- 19mm Wrench
- 22mm Wrench
- 30mm Wrench
- Drain Pan
- Channel Locks
- Brake Fluid
- Blue Loctite
- Mallet
- Impact
- Cutting Wheel
- Crescent Wrench
- Ratchets

**Driver and Passenger Side  
Installation are the same**

### BEFORE YOU BEGIN

If you do not feel comfortable installing your Thumper Fab DEFENDER LONG TRAVEL, please see your nearest Can-Am® Dealer for installation.

# Can-Am/Defender Long Travel

SKU: TF042001



10

9



A



B



C



D



E



R

H

I



F

Q



# Can-Am/Defender Long Travel

SKU: TF042001



Front Shock: Reservoir position faces outboard of vehicle



Rear Shock: Reservoir position faces toward front of vehicle

**14**

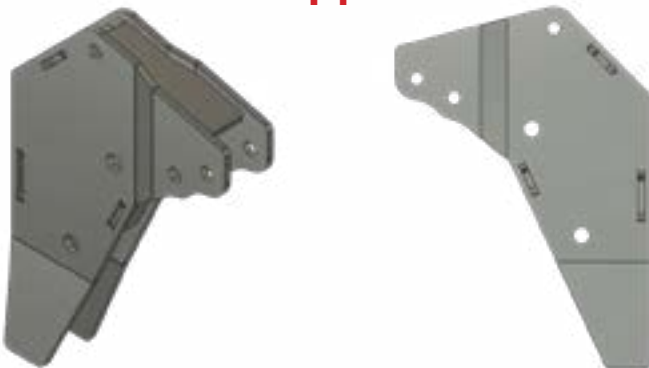

**15**



# Can-Am/Defender Long Travel

SKU: TF042001



Brake Line Hardware



Master: From master cylinder to front



Master 1: From master cylinder to rear



Master 2: Crew extension



Left Front



Right Front



Left Rear



Right Rear

# Can-Am/Defender Long Travel

SKU: TF042001



PARTS LIST	
ITEM	PART NUMBER
1	CONTROL ARM / BALL JOINT HOUSING
2	CAN-AM OEM BALL JOINT
2	RING INSERT
4	EXTERNAL RETAINING RING

**STEPS:**

1. Press ring insert into housing.
2. Press ball joint into ring insert & housing.
3. Install external retaining ring.



PARTS LIST	
ITEM	PART NUMBER
1	CONTROL ARM / BALL JOINT HOUSING
2	RING INSERT
3	BALL JOINT BODY/PIN
4	BALL JOINT CAP

**STEPS:**

1. Press ring insert into housing.
2. Press ball joint body into ring insert & housing.
3. Install ball joint internals and cap.



PARTS LIST	
ITEM	PART NUMBER
1	CONTROL ARM / BALL JOINT HOUSING
2	UNIBALL
3	INTERNAL RETAINING RING
4	UNIBALL PIN
5	MISALIGNMENT
6	NUT

**STEPS:**

1. Press uniball into housing.
2. Install internal retaining ring.
3. Insert uniball pin into uniball.
4. Install misalignment onto threaded end of uniball pin.
5. Install nut onto uniball pin.

# Can-Am/Defender Long Travel

SKU: TF042001

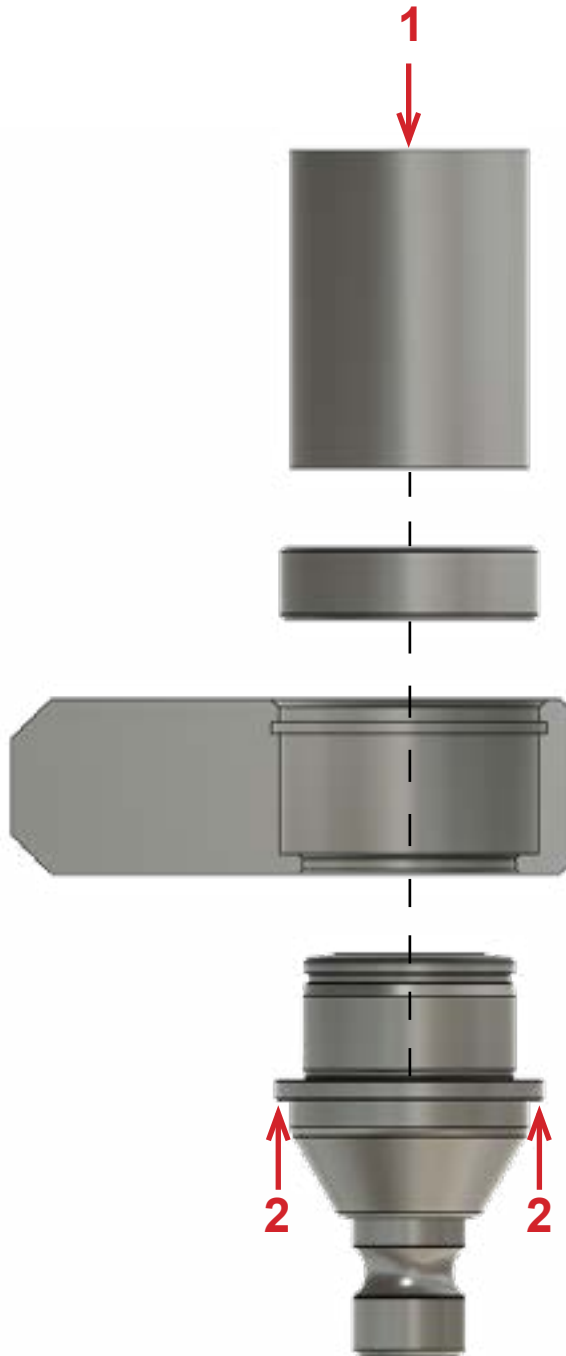

## Steps for ball joint installation:

1. Use provided installation tool to press uniball/ring insert into ball joint housing.
2. Press ball joint housing into bracket holding backup on ring insert with installation tool.

## INSTALLATION INSTRUCTIONS

### PREPARATION

1. Position Vehicle on a clean and level work area. Lift the vehicle and support with jack stands and remove wheels.



### FRONT SUSPENSION REMOVAL

2. Remove bolts fastening brake line clamps to factory arms. Then remove the 2 bolts fastening the brake caliper to the back of the knuckle assembly using a 15mm socket.



3. Remove axle cotter pins and nuts with 27mm socket. Remove hub and rotor assemblies.



## INSTALLATION INSTRUCTIONS

4. Remove the tie rod end from the hub assembly using a 15mm socket and wrench.

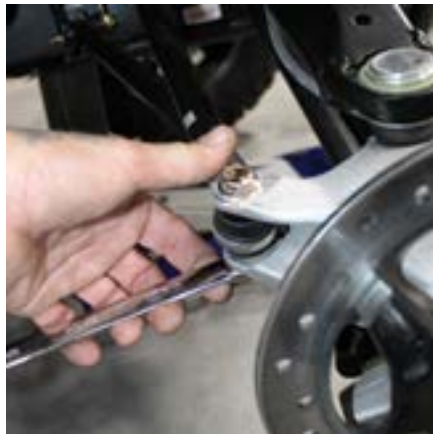

5. Unfasten the shock from the upper control arm using 15mm socket and wrench.



6. If equipped use a 15mm socket and wrench to remove the nut fastening the sway bar to the upper control arm.



## INSTALLATION INSTRUCTIONS

7. Remove the cotter pin on the upper ball joint, then use a 18mm wrench to remove the nut. A dead blow may be needed to separate upper ball joint from the knuckle.



8. Remove the cross bolt that fastens the lower ball joint to the steering knuckle using a 15mm socket and wrench.



9. Remove the upper control arm mounting bolts using 15mm socket and wrench. Remove the control arm from vehicle.



## INSTALLATION INSTRUCTIONS

10. Remove the lower control arm mounting bolts using 15mm socket and wrench. Remove the control arm from vehicle.



11. Remove axle from differential.



12. Break the clamps on the steering rack dust boot and remove tie rod from vehicle by using a crescent wrench on inner tie rod. Keep dust boot for future use.



13. Repeat for opposite side.

## INSTALLATION INSTRUCTIONS

### REAR SUSPENSION REMOVAL

14. Remove the rivets fastening brake line clamps to factory arms. Then remove the 2 bolts fastening the brake caliper to the back of the hub assembly using a 15mm socket.



15. Remove axle cotter pins and axle nuts.



16. Remove hub and rotor assemblies. Hubs are secured with Loctite from the factory. Splines may be required to be heated to remove hub.



## INSTALLATION INSTRUCTIONS

17. Remove bolts securing rear bearing carrier to upper and lower control arms using 15mm socket and wrench.



18. Remove axle from differential.



19. Remove the shock using a 15mm socket and wrench.



20. If required, remove the nut fastening the sway bar to the lower control arm using a 15mm socket and wrench.

## INSTALLATION INSTRUCTIONS

21. Remove the upper and lower control arms using 15mm socket and wrench.



22. Repeat for opposite side.

### COMPONENT PREPARATION

23. If reusing factory ball joints, remove joints from factory control arms.

24. If required, Install Uni-ball or ball joint on control arms according to provided diagrams.

25. Using a 7mm wrench remove the factory grease fittings from the stock control arms and install in your front and rear Thumper Fab control arms.



26. Install bushings, pivot sleeves, and wear plates on control arms.



## INSTALLATION INSTRUCTIONS

### SHOCK RELOCATION BRACKETS (ONLY IF USING STOCK SHOCKS)

27. Install the front and rear shock relocation brackets at the factory shock locations using factory hardware.



28. Install provided M10-1.5x25mm bolt, fender washer, and nut on lower mounting position.

### FRONT SUSPENSION

29. Install factory steering rack dust boot over inner tie rod taking care not to damage boot. Secure with cable tie and thread on jam nut up to dust boot.



30. Apply blue Loctite to the inner tie rod. Thread into steering rack and tighten using crescent wrench.



## INSTALLATION INSTRUCTIONS

31. (OPTIONAL) Install steering stop if desired on steering rack shaft.

**Warning: not using steering stop can cause premature axle boot failure.**



32. Secure dust boot to steering rack with cable tie.

33. Using a 15mm socket and wrench install the lower control arm using factory hardware.



34. Install axle into front differential.



## INSTALLATION INSTRUCTIONS

35. Install upper arm using factory hardware and 15mm socket and 15mm wrench.



36. Attach steering knuckle to lower control arm using factory cross-bolt.



37. Attach upper ball joint to steering knuckle using 18mm wrench.



## INSTALLATION INSTRUCTIONS

38. Install wheel hub and rotor assembly and secure using 30mm socket with supplied axle nut and washer applying anti-seize to splines of joint.



39. Using a 15mm socket and wrench install shocks and attach to control arms using factory hardware. If using shock relocation brackets on the front, use lower hole for shocks that are 20.5" long center to center and use the upper hole for shocks that are 21.25" long center to center. If installing shock relocation brackets on an HVAC unit, wrap provided wire loom around AC lines where they come close to front passenger bracket.



40. If equipped attach sway bar to control arms using a 15mm socket and wrench.  
41. Install brake caliper assembly on steering knuckle with factory hardware using blue Loctite applied to threads and 15mm socket.



## INSTALLATION INSTRUCTIONS

42. Install jam nuts onto Heim joints and thread onto tie rod bodies.

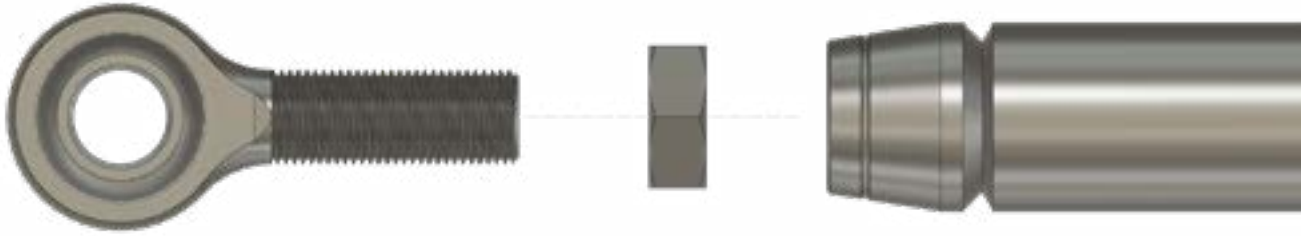

43. Install tie rod assembly on inner tie rod and attach to steering knuckle with supplied tie rod misalignments and factory hardware using a 15mm socket and wrench.



44. With the steering wheel straight perform a rough steering alignment. Do not tighten jam nuts. Full alignment will be performed when vehicle is on the ground and suspension has settled.

45. Tighten all hardware to OEM torque specifications.

46. Repeat for opposite side.

### REAR SUSPENSION

47. If using Zbroz shocks, you will need to cut 1-1/2" off the exhaust pipe to provide clearance for shock reservoir.



## INSTALLATION INSTRUCTIONS

48. Using a 15mm socket and wrench install the lower control arm using factory hardware.



49. Install axle into rear differential, applying anti-seize to splines of the outer joint.



50. Using a 15mm socket and wrench install the upper control arm using factory hardware.



## INSTALLATION INSTRUCTIONS

51. Attach rear bearing carrier to control arms using provided hardware and 15mm socket and wrench.



52. Install wheel hub and rotor assembly and secure using 30mm socket with supplied axle nut and washer. Stake the axle nut.



53. Using a 15mm socket and wrench install shocks and attach to control arms using provided hardware.



## INSTALLATION INSTRUCTIONS

54. Using a 15mm socket and wrench attach sway bar to control arms using factory hardware.



55. Install brake caliper assembly on bearing carrier applying blue Loctite factory hardware.  
Do not attach brake line.



56. Tighten all hardware to OEM torque specifications.

57. Repeat for opposite side.

## INSTALLATION INSTRUCTIONS

### BRAKE LINES

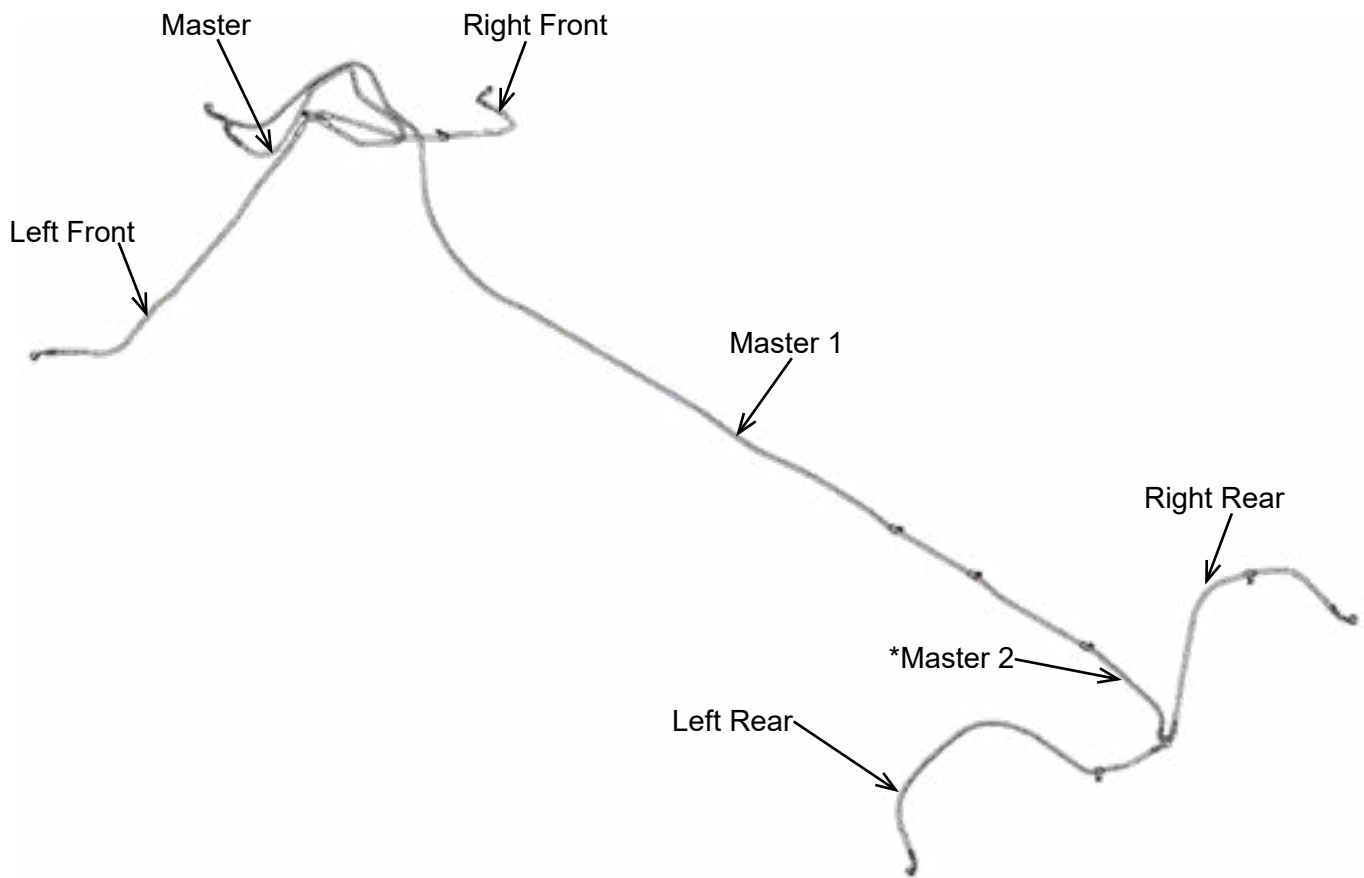

58. Replace factory brake lines with the TF brake line kit according to the above diagram. Remove stock loop clamps from factory brake lines and reuse to secure the TF brake line kits in original location. Attach the lines using provided self-tapping screws and cable ties from the hardware kit. **Note: On Limited models, AC components restrict routing of brake lines on the dash interior. For this application you may route the lines along the outside of the firewall.**



## INSTALLATION INSTRUCTIONS

59. Remove the 3 bolts and 2 rivets in the inner fender well on the front passenger side. Remove the bolt holding the brake line located by the lower rear arm bracket.



60. Raise the rear seats and remove the floor panel to aid in the removal of the brake line.



61. To access the master cylinder, remove the push-in rivet holding the panel at the driver fender well. Unplug the brake light switch. In the front of the cab.



## INSTALLATION INSTRUCTIONS

62. Remove the panel on lower dash to expose the brake lines.



63. Use a 12mm wrench to disconnect the front main brake line. Remove brake line and replace with the TF front main line (Master) and T block.



64. Using a 14mm wrench disconnect the rear brake line from the master cylinder. Remove the rear brake line that runs through the middle floor of the unit. Replace with the long brake line (Master#1) and T block. **Add the union and crew extension (Master#2) for Defender Max models only.**



## INSTALLATION INSTRUCTIONS

65. Remove and replace remaining lines according to the provided diagram. Use the stock banjo bolt and supplied copper washers on each side of banjo to attach lines to brake caliper.



66. Fasten brake lines to control arms using provided cable ties. Be sure the brake lines do not rub the axles.



### FINAL STEPS

67. Apply grease to all control arm grease fittings.
68. Ensure all hardware is tightened to OEM torque specifications.
69. Reinstall wheels and tires and return vehicle to ground
70. Bleed all 4 calipers starting with the farthest away from the master cylinder and working toward the master cylinder adding fluid as necessary. Be sure to remove all the air from the lines as this will greatly reduce braking ability.
71. Adjust spring settings if desired.
72. Perform final steering alignment.

## INSTALLATION INSTRUCTIONS

The installation of products sold or manufactured by Thumper Fab including, but not limited to suspension components such as lift kits, control arms, frame stiffener kits, roofs, roll cages, and tires that exceed the original specifications for the vehicle, may change the vehicle's center of gravity and handling characteristics both on and off-road. You are aware that the installation of tires that are larger than original vehicle specifications may reduce the effectiveness of the braking system. Use of these products may place added stress to the original factory vehicle components which could cause them to weaken or possibly fail.

Products sold or manufactured by Thumper Fab are intended for off-road use only. Operation of a vehicle modified with these products on a road could result in serious bodily injury or death, and such operation may violate the laws of your state or municipality. You agree to operate your vehicle exclusively in the manner intended by the vehicle manufacturer. You agree that failure to safely and reasonably operate your vehicle could result in serious bodily injury or death, and that, as a result of installation of this product(s) to your vehicle, extreme care must be taken to prevent vehicle rollover or loss of control, which may be more likely to occur as a result of said modifications. You will avoid unsafe maneuvers, including sudden sharp turns or other abrupt maneuvers, which could make a vehicular accident more likely. You understand that Thumper Fab is not responsible or liable for any damages or any injuries to yourself or your passengers that could occur upon possible accidents due to driver error, incorrect installations, bad judgment, incompatibility with other aftermarket accessories or natural disasters to the fullest extent allowable by law. You will have all vehicle occupants fasten seat belts, if equipped, and wear proper safety equipment, such as DOT approved helmet and eye protection prior to operating the vehicle. You understand and acknowledge that failure to wear proper safety equipment may increase the risk of serious bodily injury or death to yourself and any passengers.

Proper installation of products sold or manufactured by Thumper Fab requires knowledge of the factory recommended procedures for removal and installation of original equipment components. Installation of these products without proper knowledge and experience may affect the performance of these components and the safety of the vehicle and cause serious bodily injury or death. It is strongly recommended that a certified mechanic familiar with the installation of similar components perform the product(s) installation.

Prior to installing any products sold or manufactured by Thumper Fab, you will perform or cause to be performed an inspection of their vehicle to confirm its condition is suitable for the installation of these products. A proper inspection of the vehicle includes confirmation that the vehicle has not been in a collision and is free of corrosion. If the vehicle is suspected to have been in a collision or misused, or is otherwise unsuitable for modification, you will not install the product(s). You will continue to inspect the vehicle prior to each use to confirm its condition is suitable for its intended use, and you acknowledge that the failure to do so may result in serious bodily injury or death, as well as damage to the vehicle itself.

You will install any warning labels provided with the product so it may be prominently seen by yourself and all passengers. You will notify all passengers of the modifications performed to your vehicle prior to operation.

Insurance companies may handle coverage of a modified vehicle differently. Please check with your insurance carrier prior to modifying the vehicle to ensure your coverage remains sufficient.

Installation of this product(s) may void your vehicle warranty. If this is a concern, please check with the manufacturer or dealer before purchase or installation of this product(s).



**THUMPER FAB**

**Thumper Fab**

5103 Elysian Fields Rd, Marshall, TX 75672

Customer Service: 903-472-0928

[www.thumperfab.com](http://www.thumperfab.com)