



THUMPER FAB

Aluminum Audio Roofs ♦ Roll Cages ♦ UTV Accessories

Polaris Ranger Long Travel Kit

SKU: TF012001

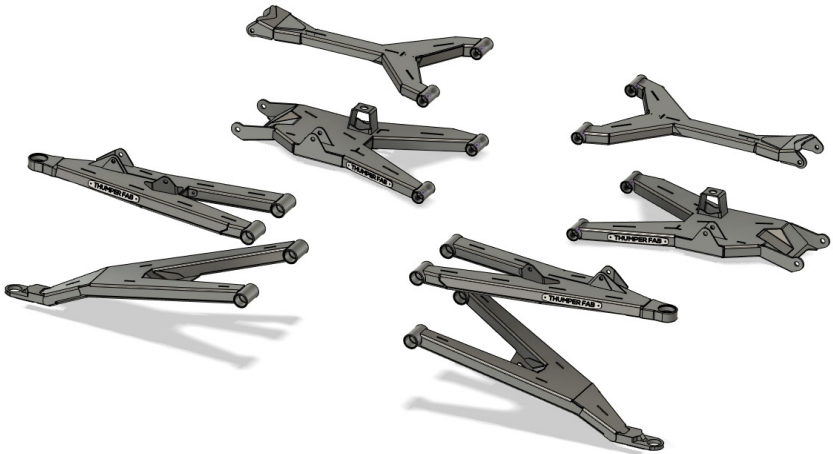

Thumper Fab

5103 Elysian Fields Rd, Marshall, TX 75672

Customer Service: 903-472-0928

www.thumperfab.com

Ver. 0323

Polaris Ranger

Long Travel Kit

SKU: TF012001



PARTS

REF	QTY	DESCRIPTION
1	1	Driver Front Upper Arm
2	1	Driver Front Lower Arm
3	1	Driver Rear Upper Arm
4	1	Driver Rear Lower Arm
5	1	Passenger Front Upper Arm
6	1	Passenger Front Lower Arm
7	1	Passenger Rear Upper Arm
8	1	Passenger Rear Lower Arm
9	2	Tie Rods (Main Bodies)
10	4	Brake Line Kit
11	4	Axles
12	4	ZBros Shocks
13	2	Steering Boots
HARDWARE KIT		
A	2	Inner Tie Rods
B	2	5/8"-18 LHT Heim Joint
C	2	5/8"-18 LHT Jam Nuts
D	2	Standoff A
E	2	Standoff B (Tapered)
F	2	1/2"-13 x 3" Flange Bolt
G	2	1/2"-13 Flange Lock Nut
H	12	Zip Ties
I	2	Steering Stops
J	8	Shock Misalignments (Only used with ZBros Shocks)
K	2	Ball Joint Rings (Stock Ball Joints and Kellers Style Only)
L	2	Ball Joint Housing Caps

TOOLS

- Impact
- Mallet
- Drain pan
- Grinder or Cut-Off Wheel
- Needle Nose Pliers
- 13mm Socket
- 15mm Socket
- 18mm Socket
- 19mm Socket
- 27mm Socket
- 11mm Wrench
- 12mm Wrench
- 13mm Wrench
- 15mm Wrench
- 18mm Wrench
- 19mm Wrench
- 22mm Wrench
- Brake Fluid
- Blue Loctite

BEFORE YOU BEGIN

If you do not feel comfortable installing your **Thumper Fab** Long Travel Kit, please see your nearest Polaris® Dealer

Polaris Ranger

Long Travel Kit

SKU: TF012001



NOTE:

1. *Ball Joint Housing Caps (L) and Ball Joint Rings (K) are only supplied if you are installing your own factory ball joints or aftermarket ball joint.*

2. *Shock Misalignments (J) are only used if you are using ZBroz shocks.*

INSTALLATION INSTRUCTIONS FOR BALL JOINTS

KELLER

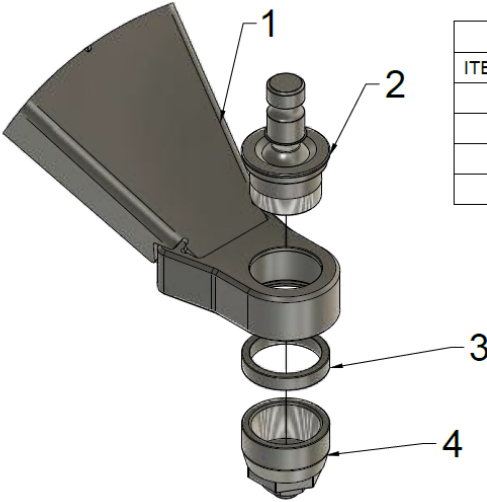

PARTS LIST	
ITEM #	DESCRIPTION
1	CONTROL ARM / BALL JOINT HOUSING
2	KELLER - TOP PORTION
3	RING INSERT
4	KELLER - CAP

1. Press RING INSERT into housing first.
2. Press KELLER - TOP PORTION into HOUSING and RING INSERT.
3. Install ball joint internals.
4. Install KELLER - CAP and set adjustment for ball joint.

KELLER - TAPERED

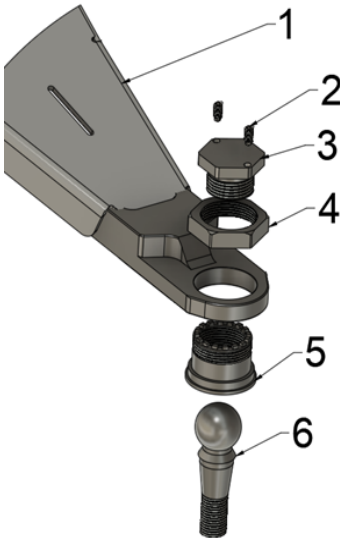

PARTS LIST	
ITEM #	DESCRIPTION
1	CONTROL ARM / BALL JOINT HOUSING
2	KELLER - SET SCREWS
3	KELLER - BUSHING ADJUSTER
4	KELLER - JAM NUT
5	KELLER - MAIN BODY
6	KELLER - BALL PIN

1. Press MAIN BODY into housing first.
2. Reinstall KELLER - BALL PIN into KELLER - MAIN BODY.
3. Fasten KELLER - JAM NUT.
4. Install KELLER - BUSHING ADJUSTER
5. Tighten KELLER - SET SCREWS

INSTALLATION INSTRUCTIONS FOR BALL JOINTS

OEM

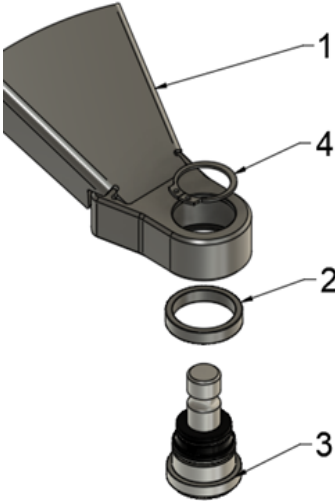

PARTS LIST	
ITEM #	DESCRIPTION
1	CONTROL ARM / HOUSING
2	RING INSERT
3	POLARIS OEM BALL JOINT
4	EXTERNAL RETAINING RING

1. Press in RING INSERT into HOUSING first.
2. Press in OEM BALL JOINT into RING INSERT & HOUSING.
3. Install EXTERNAL RETAINING RING.

UNIBALL

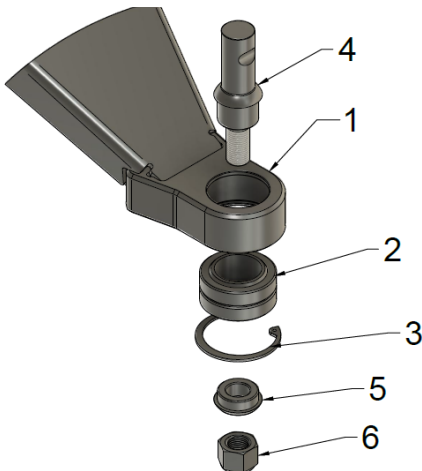

PARTS LIST	
ITEM #	DESCRIPTION
1	CONTROL ARM / BALL JOINT HOUSING
2	UNIBALL
3	INTERNAL RETAINING RING
4	UNIBALL PIN
5	MISALIGNMENT
6	LOCKNUT

1. Press in UNIBALL into HOUSING.
2. Install INTERNAL RETAINING RING.
3. Insert UNIBALL PIN into UNIBALL.
4. Install MISALIGNMENT onto threaded end of UNIBALL PIN.
5. Thread and tighten LOCKNUT onto UNIBALL PIN.

INSTALLATION INSTRUCTIONS

Removal of Factory Control Arms

Place the UTV into park. Use a jack and jackstands to lift and secure the UTV then remove the tires, shocks, brake calipers, rotors, knuckles, exhaust spring, control arms, tie rods, front bumper, and winch (**FIG 1**).



FIG 1 - Prepare Ranger by Removing Parts to Access Arms

Front A-Arm Installation

Loosely install lower A-Arm using factory hardware using 18mm socket and 18mm wrench. Apply anti-seize to both ends of the axles and install axles into front differential (**FIG 2**). Attach lower A-Arm to knuckle using 22mm socket. Discard the washer on the axle and use factory “thick” washer to use with axle nut (**FIG 3**).



FIG 2 - Use Anti-Seize on Axles



FIG 3 - Install Axle

INSTALLATION INSTRUCTIONS

Installation of Tie Rod and Steering Stop

Turn steering wheel to help ease access to inner band then bust inner band loose on tie rod to allow steering rack boot to be pulled back. Use crescent wrench to loosen inner tie rod and remove factory tie rod from the UTV (**FIG 4**). Install the Polaris steering stop onto the worm gear on both sides of the steering rack (**FIG 5**).



FIG 4 - Remove Factory Tie Rod



FIG 5 - Install Polaris Steering Stop onto Worm Gear Shaft (OPTIONAL)

Assemble inner tie rod by sliding new steering rack boot over inner rod (**FIG 6**). Apply blue loctite to inner tie rod before threading into steering rack and tighten using a crescent wrench. Use 4 x zip ties to seal steering rack boot to steering rack and inner tie rod (**FIG 7**).



FIG 6 - Slide Steering Boot over Inner Tie Rod



FIG 7 - Tighten Inner Tie Rod to Steering Rack Using Crescent Wrench

INSTALLATION INSTRUCTIONS

Thread tie rod body onto inner tie rod keeping the jam nut loose to allow for adjustment toe adjustment (**FIG 8**).



FIG 8 - Install Tie Rod Main Body onto Inner Tie Rod

Installation of New Brake Lines

Using a drain pan drain remove the front brake lines and replace with the provided brake lines with banjo bolt ends using 22mm wrench and 13mm socket (**FIG 9**). Be careful to save factory crush washers and banjo bolts as they will be reused. The short brake line goes to the drivers side and the long line goes to the passenger side (**FIG 10**).



FIG 9 - Remove Factory Brake Lines



FIG 10 - Install New Brake Lines

INSTALLATION INSTRUCTIONS

Installation of Upper Control Arms

Using factory mounting bolts loosely install the upper control arm to the frame using 18mm socket and 18mm wrench. Mount the upper ball joint to the knuckle using factory upper ball joint cross pin bolt and nut using 15mm wrench and 15mm socket (**FIG 11**).



FIG 11 - Install Upper Control Arm using 18mm Socket and 18mm Wrench

Mount brake rotor and calipers to the knuckle using factory hardware and 15mm socket. Tighten axle nut using 27mm socket and install cotter pin into castle nut to lock nut in place. Use 4 of the provided zip ties to fasten the new brake line to the upper control arm in the zip tie slots found on the underside of the upper arm (**FIG 12**).



FIG 12 - Mount Brake Rotor and Caliper using factory hardware. Fasten Brake Line to upper arm using Zip Ties

INSTALLATION INSTRUCTIONS

Axle Clearance (If Needed)

Check for clearance between the axle boot and the frame tabs that the lower control arm mounts to. A grinder may be used to add clearance to prevent contact with the axle boot at full droop. Grinding of the lower control arm mounting bolts may be necessary as well. Ensure adequate clearance so that boot band will not contact anything (**FIG 13**).



FIG 13 - Use a grinder to clearance frame tabs to prevent contact with the axle boot.

INSTALLATION INSTRUCTIONS

Reinstall the sway bar using the factory hardware using 15mm wrench and 15mm socket (**FIG 14**).

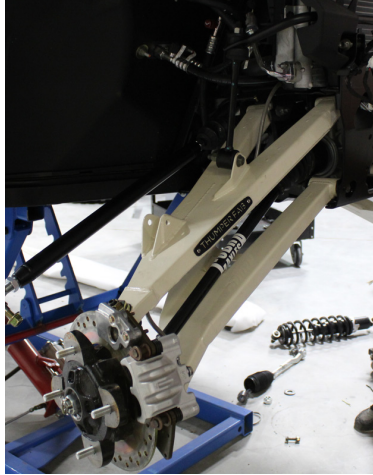

FIG 14 - Fasten Sway Bar to Upper Control arm using Factory Hardware

Thread 2 X LHT 5/8"-18 jam nuts onto 2 X LHT 5/8"-18 heim joints before threading heim joints into tie rod body. Do not tighten jam nuts until toe has been properly adjusted. Fasten heim joints to knuckle using 2 X 1/2"-13 x 3" flange bolts and 2 X 1/2"-13 flange lock nuts with Standoff A on top of heim joint and Standoff B (Tapered) inserted into the knuckle. Tighten using 3/4" wrench and 3/4" socket (**FIG 15**).

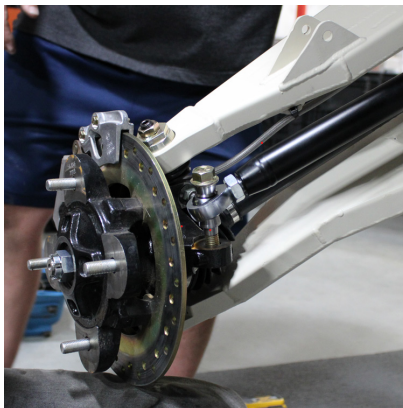

FIG 15 - Fasten Outer Tie Rod to Knuckle

INSTALLATION INSTRUCTIONS

Installation of Front Shocks (ZBroz Shocks Only) For OEM shock install refer to the end of this Installation Manual

Install misalignments (**FIG 16**) into lower shock bushings to replicate factory shock bushing width before installing shock into shock brackets using factory hardware and 15mm wrench and 15mm socket (**FIG 17**). Once shocks have been installed, tighten all hardware.



FIG 16 - Install Misalignments into Shock Bushing

FIG 17 - Install ZBRO Shocks using 15mm Socket and 15mm Wrench

INSTALLATION INSTRUCTIONS

IF YOU ARE USING A FACTORY BUMPER

Reinstall the front bumper to mark the front bumper to show where to lower control arm would contact factory bumper use a grinder/cutoff wheel to trim to allow for maximum control arm travel (**FIG 18**). Apply touch up paint if necessary.



FIG 18 - Mark Front Bumper for Clearancing with Grinder

Remove bumper, once the material has been removed from the bumper, reinstall bumper and verify adequate clearance to allow for maximum control arm extension without bumper contact (**FIG 19**).

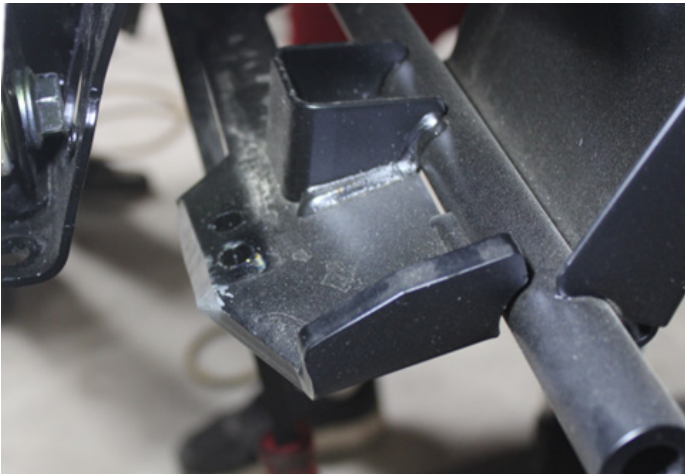

FIG 19 - Use Grinder to clearance Front Bumper

INSTALLATION INSTRUCTIONS

Rear Control Arm Installation

Install the factory sway bar link to the lower control arm using a 15mm wrench and an 8mm wrench to prevent the sway bar link from spinning (FIG 20).



FIG 20 - Fasten Outer Tie Rod to Knuckle

Using factory hardware with 19mm wrench and 19mm socket to loosely fasten lower control arm to rear frame (FIG 21).



FIG 21 - Attach Lower Control Arm to Frame

INSTALLATION INSTRUCTIONS

Apply anti-seize to both ends of the axle. Carefully insert axle into rear differential taking care not to rip the axle boot (**FIG 22**). Slide the axle through the rear knuckle before loosly fastening knuckle to lower control arm using factory hardware with 18mm socket and 18mm wrench (**FIG 23**).

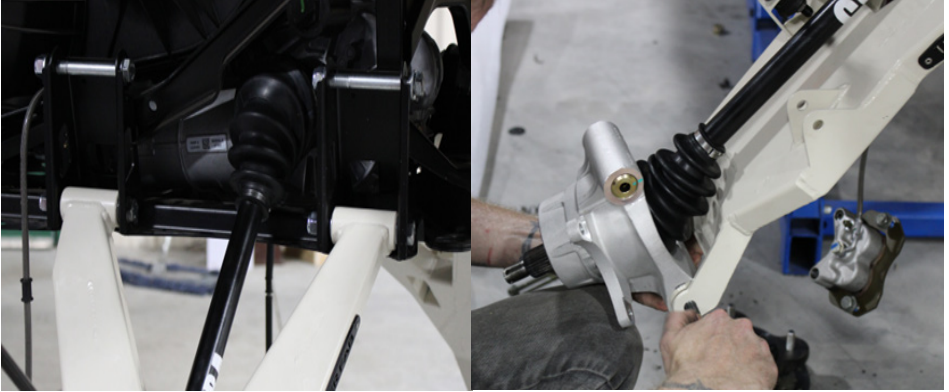

FIG 22 - Slide axle into Rear Differential

FIG 23 - Loosely mount Rear Knuckle

Using factory hardware with 19mm wrench and 19mm socket to loosely fasten upper control arm to the frame and 15mm socket and 15mm wrench to fasten the rear knuckle to upper control arm (**FIG 24**).



**FIG 24 - Install Upper Control Arm using
19mm Socket and 19mm Wrench**

INSTALLATION INSTRUCTIONS

Attach sway bar link to sway bar using factory hardware with 15mm wrench to tighten nut and 8mm wrench to prevent sway bar link from spinning while tightening factory nut (**FIG 25**).



FIG 25 - Fasten Sway Bar Link to Sway Bar

Prepare drain pan to catch dripping brake fluid. Remove factory rear brake lines from junction block (**FIG 26**) and from rear calipers using a 11mm wrench (**FIG 27**). Be careful to save crush washers and banjo bolts from rear calipers as they will be reused.

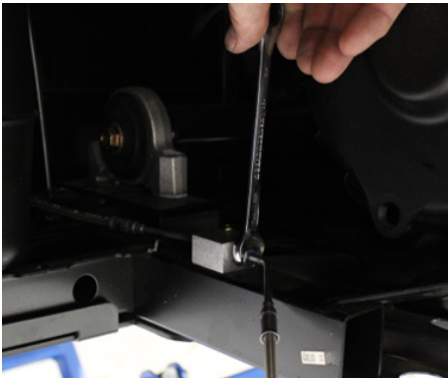

FIG 26 - Remove Rear Brake Lines from Junction Block using 11mm Wrench



FIG 27 - Remove Banjo bolt and brake line from Rear Calipers using 13mm Wrench

INSTALLATION INSTRUCTIONS

Install provided brake line adapter fittings into factory block using 12mm wrench (**FIG 28**). Install new brake lines onto the adapter fittings using 13mm wrench then route them toward their respective wheel. The short line goes to the driver side (**FIG 29**).



FIG 28 - Install Brake Line Adapter Fittings using 12mm Wrench



FIG 29 - Install Rear Brake Lines using 11mm Wrench

Mount the hubs and rotors to the rear knuckles using a 27mm socket. Once the axle nut is tight, install cotter pin in axle castle nut to prevent loosening of castle nut (**FIG 30**). Mount the caliper on the rear knuckle using factory hardware and a 15mm socket to tighten the bolts. Use a 13mm socket to attach the banjo end of the brake line to the caliper using the factory banjo bolt and crush washers (**FIG 31**).



FIG 30 - Install Hub and Rotor using axle nut and factory thick washer



FIG 31 - Fasten Caliper end of Brake line using 13mm Socket using Factory Bolt and Hardware

INSTALLATION INSTRUCTIONS

Fasten brake lines to top side of upper control arms using 4 X zip ties provided in the hardware kit (**FIG 32**).



FIG 32 - Fasten brake lines to Upper Control Arm using Zip Ties

Bleed all 4 calipers starting with the farthest away from the master cylinder and working toward the master cylinder. Be sure to remove all air from the lines before moving on from a given wheel and moving closer to the master cylinder. Air caught in the lines can greatly reduce braking ability. Tighten all remaining hardware for control arm frame mounts, shock mounts, etc. and lower unit to the ground and adjust toe as needed. Enjoy your new Thumper Fab Long Travel!!!

Polaris Ranger

Long Travel Kit (OEM SHOCKS ONLY)

SKU: TF012001



PARTS

REF	QTY	DESCRIPTION
1	1	OEM Front Shock Relcation Bracket
2	4	OEM Rear Shock Relocation Bracket
HARDWARE KIT		
A	2	M10-1.5 x 35mm Flange Bolt
B	8	M10-1.5 x 65mm Flange Bolt
C	10	M10-1.5 Flange Lock Nut
D	20	M10 Flat Washers
E	8	Spacer

BEFORE YOU BEGIN
 If you do not feel comfortable installing your **Thumper Fab** Long Travel Kit, please see your nearest Polaris® Dealer

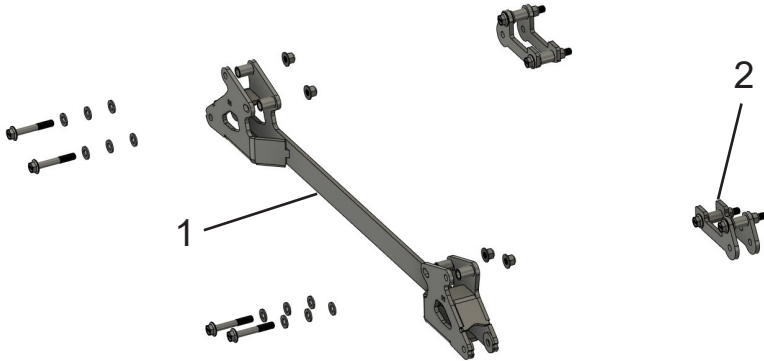

INSTALLATION INSTRUCTIONS

Installation of Front OEM Shock Relocation Brackets

If using the OEM shocks, shock relocation brackets must be used in the front and the rear. Install the OEM Front Shock Relocation Bracket as shown below. The flat bar that stretches from either end of the bracket should be towards the firewall. Insert the bracket so that it fits into the front side of each of the shock mount tabs on the chassis. (FIG 33-36).



FIG 33



FIG 34



FIG 35



FIG 36

Using 2 X M10-1.5 x 35mm flange bolts, M10 washers, and M10 locknuts, fasten the bracket as shown below. The washers will be placed between the bracket and the front-most shock tab. Next insert one of the spacers in between oem frame tabs, run the bolt all the through and fasten with the M10 locknut. There are to be 2 M10 bolts, washers, spacers, and locknuts on either side of the unit. (Figure 37-40)

INSTALLATION INSTRUCTIONS

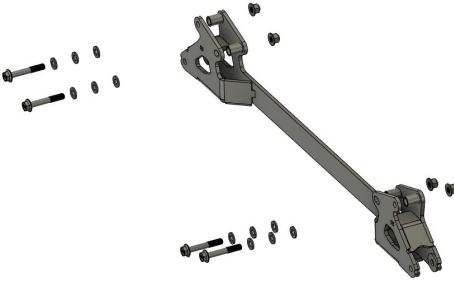

FIG 37

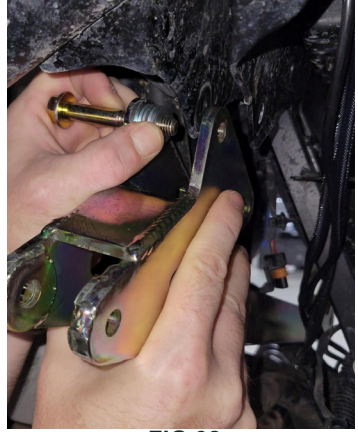

FIG 38



FIG 39



FIG 40

INSTALLATION INSTRUCTIONS

Once OEM Front Shock Relocation Bracket is tight, install OEM front shocks using factory hardware. Once upper and lower mounting bolt are snug, tighten with 15mm wrench and 15mm socket (**FIG 35**).



FIG 35 - Install OEM Shock using factory hardware and tighten with 15mm Socket and 15mm Wrench

Installation of Rear OEM Shock Relocation Brackets

Install OEM Rear Shock Relocation (**3**) using M10-1.5 x 65mm flange bolts (**B**). Slide flange bolt (**B**) through rear bracket, then remaining 8 X M10 flat washers (**D**) (2 Per Bolt) through front side of rear frame. The bolt should then slide through spacer (**4**) before going through rear bracket and the rear side of the rear frame and fastening with M10-1.5 flange lock nut (**D**) (**FIG 36**).

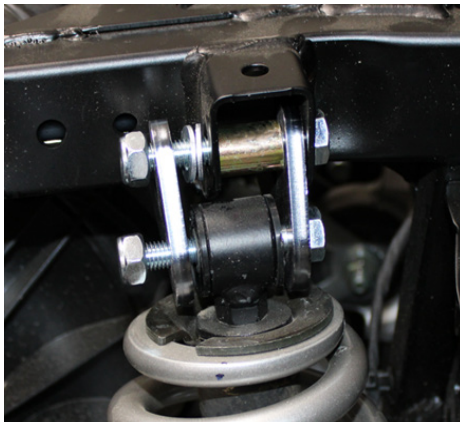

FIG 36 - Install OEM Rear Shock Relocation Brackets and tighten using 15mm Socket and 15mm Wrench

INSTALLATION INSTRUCTIONS

Once OEM Rear Shock Relocation Brackets (3) are tight, install OEM rear shocks using factory hardware. Tighten factory hardware using 15mm socket and 15mm wrench (FIG 37).

Note: If unit has electric bed lift, rear brackets on passenger side may have to be clearanced slightly to avoid contact with the electric bed lift while in operation.

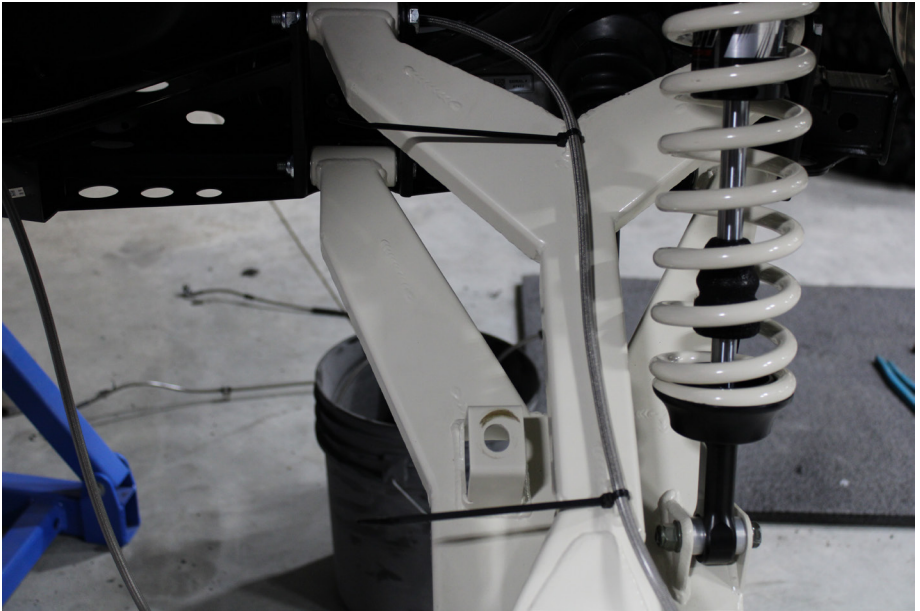

FIG 37 - Install OEM Shock using factory hardware and tighten with 15mm Socket and 15mm Wrench

The installation of products sold or manufactured by Thumper Fab including, but not limited to suspension components such as lift kits, control arms, frame stiffener kits, roofs, roll cages, and tires that exceed the original specifications for the vehicle, may change the vehicle's center of gravity and handling characteristics both on- and off-road. You are aware that the installation of tires that are larger than original vehicle specifications may reduce the effectiveness of the braking system. Use of these products may place added stress to the original factory vehicle components which could cause them to weaken or possibly fail.

Products sold or manufactured by Thumper Fab are intended for off-road use only. Operation of a vehicle modified with these products on a road could result in serious bodily injury or death, and such operation may violate the laws of your state or municipality. You agree to operate your vehicle exclusively in the manner intended by the vehicle manufacturer. You agree that failure to safely and reasonably operate your vehicle could result in serious bodily injury or death, and that, as a result of installation of this product(s) to your vehicle, extreme care must be taken to prevent vehicle rollover or loss of control, which may be more likely to occur as a result of said modifications. You will avoid unsafe maneuvers, including sudden sharp turns or other abrupt maneuvers, which could make a vehicular accident more likely. You understand that Thumper Fab is not responsible or liable for any damages or any injuries to yourself or your passengers that could occur upon possible accidents due to driver error, incorrect installations, bad judgment, incompatibility with other aftermarket accessories or natural disasters to the fullest extent allowable by law. You will have all vehicle occupants fasten seatbelts, if equipped, and wear proper safety equipment, such as DOT approved helmet and eye protection prior to operating the vehicle. You understand and acknowledge that failure to wear proper safety equipment may increase the risk of serious bodily injury or death to yourself and any passengers.

Proper installation of products sold or manufactured by Thumper Fab requires knowledge of the factory recommended procedures for removal and installation of original equipment components. Installation of these products without proper knowledge and experience may affect the performance of these components and the safety of the vehicle and cause serious bodily injury or death. It is strongly recommended that a certified mechanic familiar with the installation of similar components perform the product(s) installation.

Prior to installing any products sold or manufactured by Thumper Fab, you will perform or cause to be performed an inspection of their vehicle to confirm its condition is suitable for the installation of these products. A proper inspection of the vehicle includes confirmation that the vehicle has not been in a collision and is free of corrosion. If the vehicle is suspected to have been in a collision or misused, or is otherwise unsuitable for modification, you will not install the product(s). You will continue to inspect the vehicle prior to each use to confirm its condition is suitable for its intended use, and you acknowledge that the failure to do so may result in serious bodily injury or death, as well as damage to the vehicle itself.

You will install any warning labels provided with the product so it may be prominently seen by yourself and all passengers. You will notify all passengers of the modifications performed to your vehicle prior to operation.

Insurance companies may handle coverage of a modified vehicle differently. Please check with your insurance carrier prior to modifying the vehicle to ensure your coverage remains sufficient.

Installation of this product(s) may void your vehicle warranty. If this is a concern, please check with the manufacturer or dealer before purchase or installation of this product(s).



Thumper Fab

5103 Elysian Fields Rd, Marshall, TX 75672

Customer Service: 903-472-0928

www.thumperfab.com