



THUMPER FAB

Aluminum Audio Roofs • Roll Cages • UTV Accessories

Polaris Ranger 1000 XP Crew NERF RAILS (Crew)

SKU: TF010703

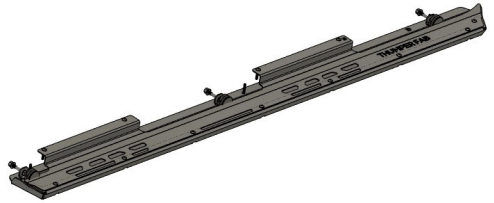
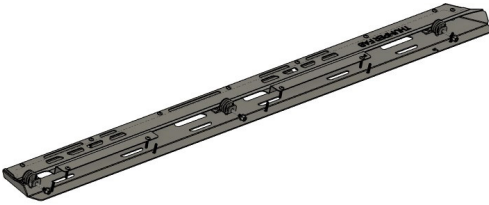

Thumper Fab

5103 Elysian Fields Rd, Marshall, Tx 75672

Customer Service: 903-472-0928

www.thumperfab.com

Ver. 0622

Polaris Ranger 1000 XP Crew NERF RAILS (Crew)



SKU: TF010703

PARTS

REF	QTY	DESCRIPTION
1	1	TOP BODY - DRIVER (D)
2	1	TOP BODY - PASSENGER (P)
3	1	BOTTOM BODY - DRIVER (D)
4	1	BOTTOM BODY - PASSENGER (P)
5	6	MOUNT BRACKET
HARDWARE		
A	12	M8 Locknut
B	6	M8 x 20mm Button Head Screw
C	6	M8 x 55mm Long, Hex Head Screw
D	18	M6 x 30mm, Button Flange Screw
E	16	M6 x 20mm, Button Flange Screw
F	16	M6 Flanged Locknut
G	6	M8 Flat Washer
H	6	1.5" Plastic Plug

TOOLS

- T30 Torx
- 4mm Allen
- 5mm Allen
- 10mm Socket
- 13mm Socket

BEFORE YOU BEGIN

If you do not feel comfortable installing your **Thumper Fab** INSERT PRODUCT, please see your nearest INSERT BRAND® Dealer for

INSTALLATION INSTRUCTIONS

CREW NERF RAILS

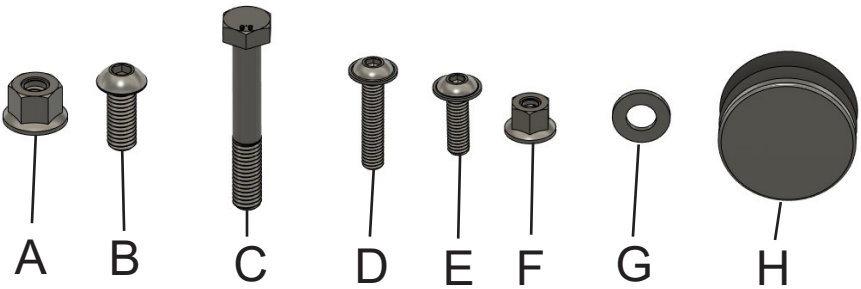
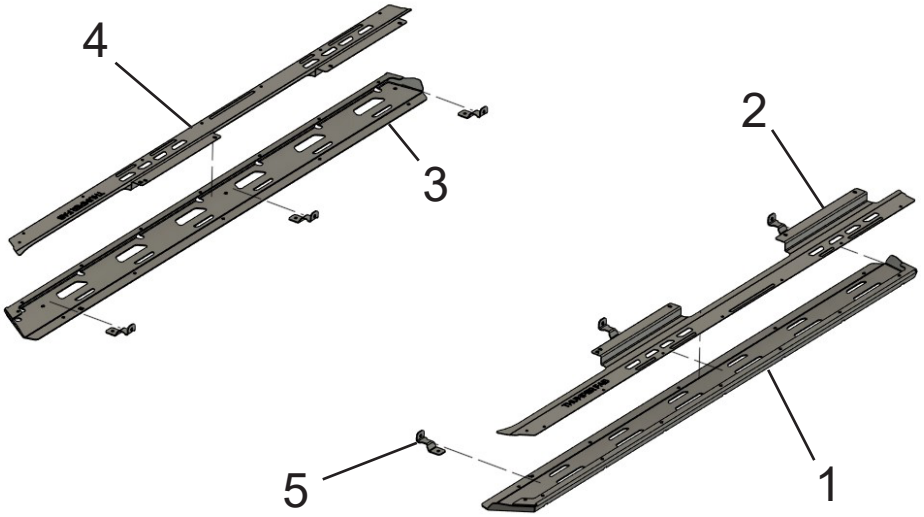

INSTALLATION INSTRUCTIONS

Drilling 1.5 Inch holes in plastic

First, start by locating the 1.5" hole saw guide in the rocker panels, provided by Polaris. Use a 1.5" hole saw or Dremel to drill these out. Clean up the edges of the holes, then move to next step.



Next, insert the mount bracket into the hole, then the M8 x 55mm Hex Head Bolt, then fasten with a M8 Locknut from underneath the unit. There will be an access pocket in the skid plate that allows access to the back side of the frame rail. Tighten the bolt/nut up just enough to remove most of the slack, but leave loose until everything is mounted.



INSTALLATION INSTRUCTIONS

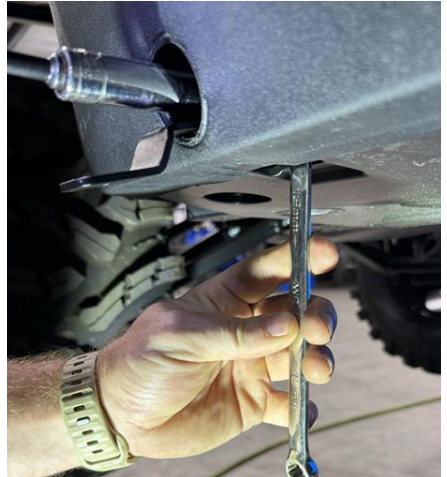

Next, remove all of the oem torx screws from the tops of the door sills and along the bottom of the rocker panel. See below.



INSTALLATION INSTRUCTIONS

Next, place to bottom of the nerf rail up into place and loosely fasten with the M6 x 30mm screws and the M8 x 20mm button head screws. The M6 x 30mm screws will replace the oem torx screws that you previously removed along the bottom of the unit. The M8 screws will go up through the bottom of the nerf rail, through the mount brackets, and fasten with an M8 flanged locknut. See below



INSTALLATION INSTRUCTIONS

Trimming Plastic Caps

Trimming a flat on the plastic end caps is recommended. It will help to ensure the cap sits flush when in contact with the mount bracket and allow the cap to be installed easier. To do this, use a file, razor blade, or dremel to trim a flat spot on the cap. trim all the way back to the inside corner



INSTALLATION INSTRUCTIONS

Next, with all hardware still relatively loose, place the top of the nerf rail in place. Confirm that all of the upper holes/slots align with the hole in the door sill and with the bottom body of the nerf rail. Make adjustments as necessary. Once you know everything will align properly, set the top body of nerf rail aside and tighten all installed hardware. Then install the plastic cap into place.

Then, re-place the top body of the nerf rail. Loosely thread more of the M6 x 30mm screws into the door sills, replacing the oem torx screws. Also, insert the M6 x 20mm down through the top and bottom bodies and fasten with with the M6 locknuts from underneath the nerf rail. Make sure all hardware has been tightened.

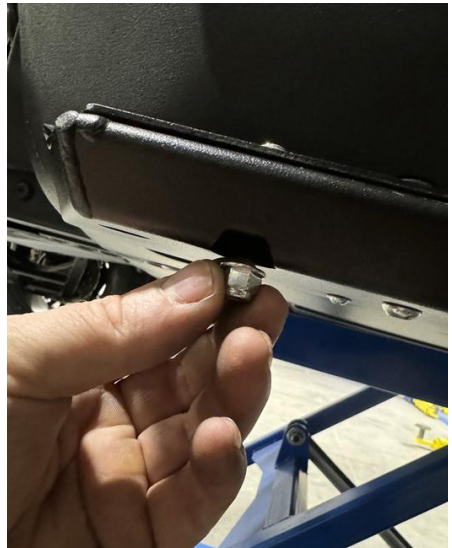



THUMPER FAB

Thumper Fab

5103 Elysian Fields Rd, Marshall, Tx 75672
Customer Service: 903-472-0928

www.thumperfab.com