



**DIRECT-REPLACEMENT  
INSTALLATION GUIDE**

**POLARIS RANGER XP1000 (2019-ON)**

---

# **2.0 PODIUM SHOCKS**

---

885-06-132 - Kit: Polaris, AM Ranger XP1000, Full Vehicle, 2.0" QS-3, Performance Series

885-06-136 - Kit: Polaris, AM Ranger Crew XP1000, Full Vehicle, 2.0" QS-3, Performance Series

# CONTENTS

---

<b>INTRODUCTION</b>	<b>1</b>
<b>SHOCK DIAGRAM</b>	<b>2</b>
<b>SAFETY INSTRUCTIONS</b>	<b>3</b>
<b>INSTALLATION GUIDELINES</b>	<b>4</b>
<b>FRONT INSTALLATION</b>	<b>5</b>
<b>REAR INSTALLATION</b>	<b>7</b>
<b>WARRANTY INFORMATION</b>	<b>9</b>
<b>SHOCKS NEED LOVE TOO</b>	<b>10</b>

# INTRODUCTION

---

Thank you for choosing FOX direct replacement shocks for your vehicle. FOX products are designed, tested, and manufactured by the finest professionals in the industry.

FOX recommends that you become completely familiar with the handling characteristics of your modified vehicle before operating it under rigorous conditions, helping to avoid potential rollover situations and other loss of control events. FOX further recommends that you use appropriate protective equipment at all times when operating your vehicle.

To achieve the best performance and product longevity, periodic service and maintenance is required. Please refer to the Service and Upgrades section for more information.

## IN THE BOX

- Front Shocks
- Rear Shocks
- Installation Manual

# SHOCK DIAGRAM

## FRONT SHOCK

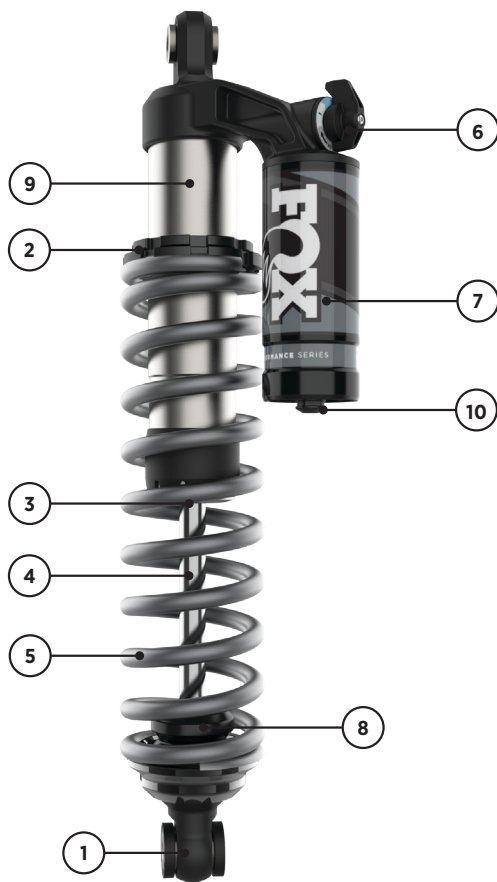

## REAR SHOCK

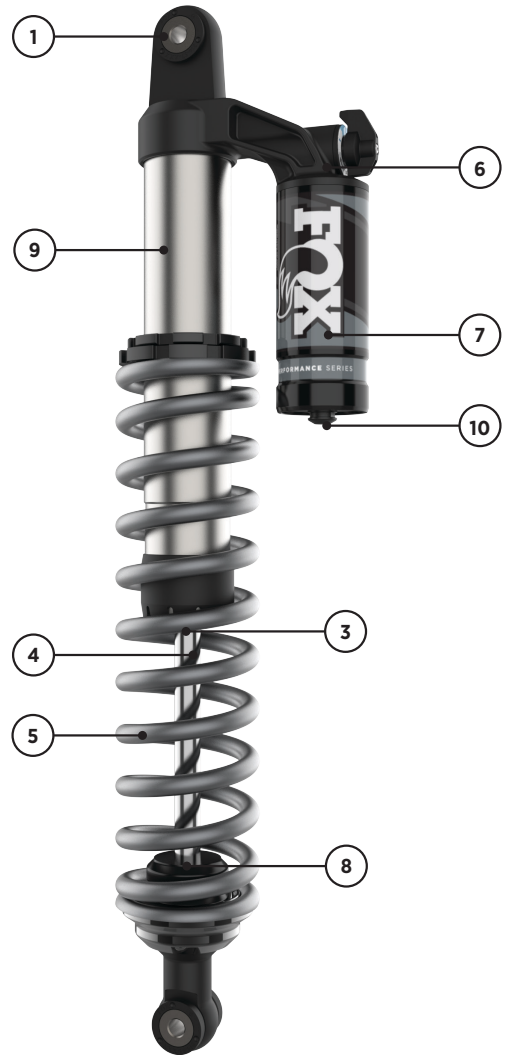

PART NO.	NAME	PART NO.	NAME
1	Eyelet	6	QS3 adjuster
2	Preload ring	7	Reservoir
3	Wiper seal	8	Bumper
4	Shaft	9	Shock body
5	Spring	10	Schrader valve

## WARNING

# SAFETY INSTRUCTIONS

---

- FOX direct-replacement shocks are designed to fit and allow proper clearance with the factory suspension. If aftermarket suspension components are installed it is the customers responsibility to ensure that at full cycle the suspension clears the FOX shocks.
- FOX direct-replacement shocks should always be installed as a set for maximum performance.
- Proper installation and service procedures are essential for the safe and reliable operation of the suspension components, requiring the experience and tools specially designed for this purpose. Installation and maintenance procedures for this product must be performed by a qualified service technician, to avoid potentially unsafe vehicle handling characteristics, which may result in **SERIOUS INJURY** or **DEATH**.
- Modifying your vehicle's suspension will change the handling characteristics of your vehicle. Under certain conditions, your modified vehicle may be more susceptible to loss of control or rollover, which can result in **SERIOUS INJURY** or **DEATH**. Thoroughly familiarize yourself with the modified vehicle handling characteristics before any rigorous vehicle operation. Wear protective body gear and a helmet when appropriate. Installation of vehicle roll bars or cage is highly recommended.
- FOX direct-replacement shocks are gas-charged and are highly pressurized. Placing shocks in a vise or clamp, applying heat, or attempting to open or service the shock without the proper tools and training can result in **SERIOUS INJURY** or **DEATH**. Do not attempt to modify, puncture or incinerate a FOX direct-replacement shock absorber.
- Any attempt to misuse, misapply, modify, or tamper with any FOX product voids any warranty and may result in **SERIOUS INJURY** or **DEATH**.

## WARNING

# INSTALLATION GUIDELINES

---

- Always use a chassis lift for the installation of shocks, and make certain that the raised vehicle is securely attached to the lift to prevent the vehicle from slipping, falling, or moving during the installation process.
- DO NOT install any FOX product without the necessary special tools, expertise and chassis lift or you will subject yourself to the risk of SERIOUS INJURY or DEATH. If you elect to not use a chassis lift (which may result in SERIOUS INJURY or DEATH), ensure that the vehicle is: (1) on level ground, (2) that all tires on the ground during installation are blocked to prevent vehicle movement, (3) that at least two tires are on the ground at all times, and (4) that adequately secured jack stands are used to support the vehicle. NEVER get under the vehicle until you have checked to ensure that the vehicle will be stable during installation.
- FOX direct-replacement shocks are designed to fit your vehicle's shock mounts without modification except the reservoir placement on specific models and applications.
- If a preload adjustment is necessary for your application, it may be easier to adjust preload with the shock off the vehicle. Remove the shock from the vehicle and use a spring compressor to remove the spring hardware and spring. Once the spring is removed, you can adjust the preload ring. If you cannot reach your optimal ride height within the shock's available preload adjustment, you will need to go up in spring rate to one that fits the application.

# FRONT SHOCK INSTALLATION

## TOOLS REQUIRED

- Manufacturer Torque Specs
- Torque Wrench
- Medium-Strength Thread Lock

## STOCK SHOCK REMOVAL

**NOTICE:** Medium-strength thread lock is recommended on all bolts.

1. Please read the INSTALLATION GUIDELINES on page 5 for instructions on how to properly lift and secure the vehicle.

**NOTICE:** Ensure vehicle is at full droop during installation.

2. Remove the stock shock assembly (Fig. 1 & 2).

**NOTICE:** Do not discard the stock hardware. Your new FOX shocks reuse the hardware.



Fig. 1: Detach the lower shock hardware.



Fig. 2: Remove the upper shock hardware.

### FOX SHOCK INSTALLATION

3. Orient the shock assembly so the piggyback reservoir points toward the rear of the vehicle.

4. Install the upper and lower mount with the OEM hardware (Fig. 3 & 4). Torque the hardware to the manufacturer's specifications.



Fig. 3: Install the shock's lower mount.

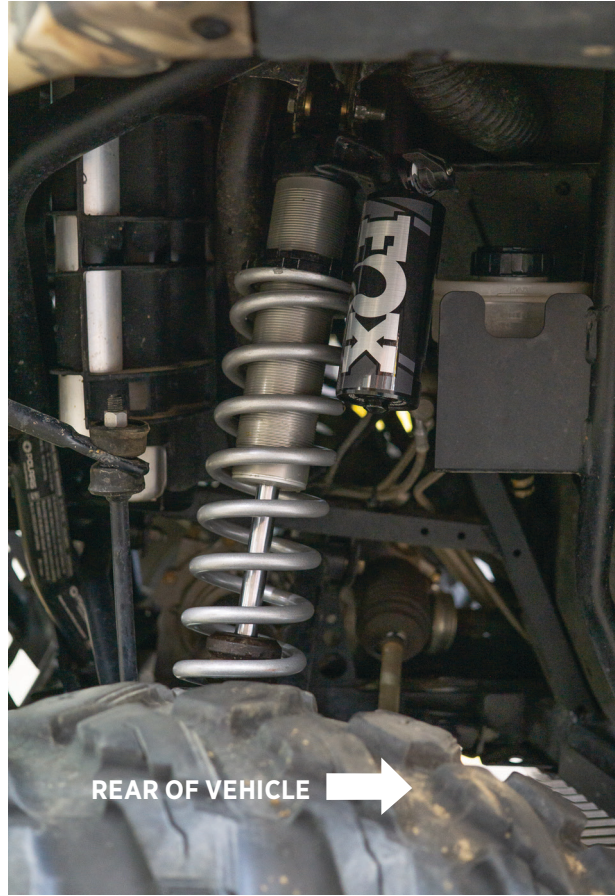

Fig. 4: The left side of the vehicle is pictured.



# REAR SHOCK INSTALLATION

## STOCK SHOCK REMOVAL

**NOTICE:** Medium-strength thread lock is recommended on all bolts.

1. Please read the INSTALLATION GUIDELINES on page 5 for instructions on how to properly lift and secure the vehicle.

**NOTICE:** Ensure vehicle is at full droop during installation.

2. Remove the stock shock assembly (Fig. 5 & 6).

**NOTICE:** Do not discard the stock hardware. Your new FOX shocks reuse the hardware.



Fig. 5: Detach the lower shock hardware.



Fig. 6: Remove the upper shock hardware.

## FOX SHOCK INSTALLATION

3. The orientation of the shock depends on the vehicle application.

**2-DOOR MODELS:** Utilize the shock mount on the inboard side of the frame and point the shock's piggyback reservoir outboard (Fig. 7).

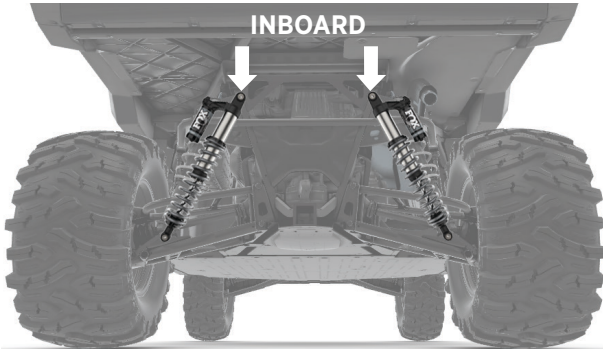

Fig. 7: Use inboard shock mount for the 2-Door.

**4-DOOR MODELS:** Utilize the shock mount on the outboard side of the frame and point the shock's piggyback reservoir inboard (Fig. 8).

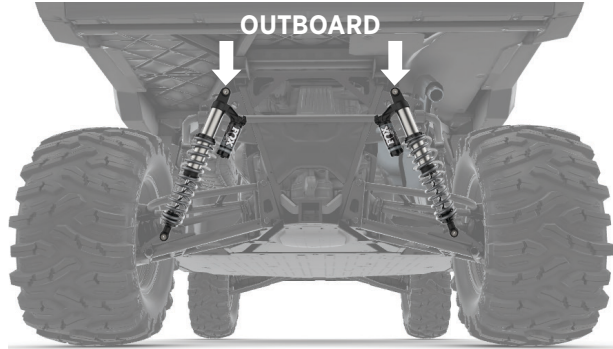

Fig. 8: Use outboard shock mount for the 4-door.

4. Install the upper and lower mount with the OEM hardware (Fig. 7 & 8). Torque to OEM specifications.



Fig. 9: Torque to OEM specification.

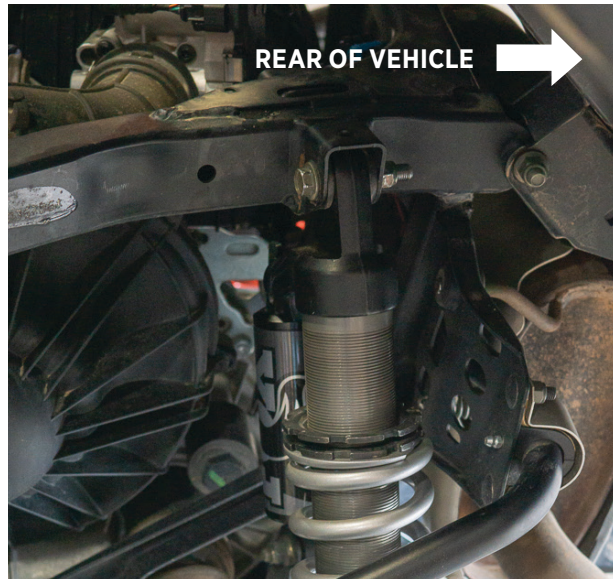

Fig. 10: The left side of a 4-door vehicle is pictured.

## CHECK AND FINAL DETAILS

5. Check that the suspension has proper clearance by steering completely in both directions.

6. Set the vehicle back on the ground and drive it back and forth several feet to allow the suspension to settle. Now measure ride height, refer to your vehicle's manual for ride height recommendation, and adjust if necessary. READ INSTALLATION GUIDELINES ON HOW TO PROPERLY ADJUST PRELOAD.

# WARRANTY INFORMATION

## FOX LIMITED WARRANTY

FOX Factory, Inc., a Georgia corporation having an office at 6634 Highway 53 Braselton, GA 30517 (“FOX”), makes the following LIMITED WARRANTY with respect to its suspension products:  
LIMITED ONE (1) YEAR WARRANTY ON SUSPENSION PRODUCTS.

Subject to the limitations, terms and conditions hereof, FOX warrants, to the original retail owner of each new FOX suspension product, that the FOX suspension product, when new, is free from defects in materials and workmanship. Unless otherwise required by law, this warranty expires one (1) year from the date of the original FOX suspension product retail purchase from an authorized FOX dealer or from a FOX authorized Original Equipment Manufacturer where FOX suspension is included as original equipment on a purchased vehicle. If law requires a warranty duration of greater than one (1) year, then, subject to the other provisions hereof, this warranty will expire at the end of the minimum warranty period required by such law.

## TERMS OF WARRANTY

This warranty is conditioned on the FOX suspension product being operated under normal conditions and properly maintained as specified by FOX. This warranty is only applicable to FOX suspensions purchased new from an authorized FOX source and is made only to the original retail owner of the new FOX suspension product and is not transferable to subsequent owners. This warranty is void if the FOX suspension product is subjected to abuse, neglect, improper or unauthorized repair, improper or unauthorized service or maintenance, alteration, modification, accident or other abnormal, excessive, or improper use.

Should it be determined by FOX in its sole and final discretion, that a FOX suspension product is covered by this warranty, it will be repaired or replaced, by a comparable model, at FOX’s sole option, which will be conclusive and binding. THIS IS THE EXCLUSIVE REMEDY UNDER THIS WARRANTY. ANY AND ALL OTHER REMEDIES AND DAMAGES THAT MAY OTHERWISE BE APPLICABLE ARE EXCLUDED, INCLUDING, BUT NOT LIMITED TO, INCIDENTAL OR CONSEQUENTIAL DAMAGES OR PUNITIVE DAMAGES.

This limited warranty does not apply to normal wear and tear, malfunctions or failures that result from abuse, improper assembly, neglect, alteration, improper maintenance, crash, misuse or collision. This limited warranty gives the consumer specific legal rights. The consumer may also have other legal rights which vary from state to state or country to country. Some states and countries do not allow the exclusion or limitation of incidental or consequential damages or warranties, and if dictated by law the above limitations or exclusions may not apply to you. If it is determined by a court of competent jurisdiction that a certain provision of this limited warranty does not apply, such determination shall not affect any other provision of this limited warranty and all other provisions shall remain in full effect.

THIS IS THE ONLY WARRANTY MADE BY FOX ON ITS SUSPENSION PRODUCTS AND COMPONENTS, AND THERE ARE NO WARRANTIES WHICH EXTEND BEYOND THE DESCRIPTION HEREIN. ANY WARRANTIES THAT MAY OTHERWISE BE IMPLIED BY LAW INCLUDING, BUT NOT LIMITED TO, ANY IMPLIED WARRANTY OF MERCHANTABILITY OR FITNESS FOR A PARTICULAR PURPOSE ARE EXCLUDED.

---

# SHOCKS NEED LOVE TOO

---

## FOX SERVICE AND UPGRADES

HAVE YOUR FOX SHOCKS SERVICED OR UPGRADED BY FOX TECHNICIANS. CALL OUR UTV SERVICE CENTER AT 831.740.4619 TO GO OVER THE SERVICE AND UPGRADE OPTIONS AVAILABLE FOR YOUR SHOCKS. ONCE YOU'VE SETUP YOUR SERVICE AND/OR UPGRADES YOU WILL RECEIVE A RETURN AUTHORIZATION NUMBER AND SHIPPING INSTRUCTIONS.

## COMPLETE SERVICES

normal use: once per season

racing or extreme use: may require more frequent service

## SERVICE MENUS AND PRICING

visit [ridefox.com/service](http://ridefox.com/service)



**WARNING: Cancer and  
Reproductive Harm –**  
[www.P65Warnings.ca.gov](http://www.P65Warnings.ca.gov)

